



# Installation manual



## CONTENT

<b>1</b>	<b>General installation</b>	<b>4</b>
<b>2</b>	<b>Safety precaution</b>	<b>5</b>
2.1	Warning	5
<b>3</b>	<b>Product identification</b>	<b>6</b>
<b>4</b>	<b>Unpacking and storing</b>	<b>6</b>
<b>5</b>	<b>Mechanical Installation</b>	<b>7</b>
5.1	Selecting the location	7
5.2	Selecting the proper support frame	7
5.3	Ground mount	9
5.4	Roof mount	9
5.5	Pole mount	10
5.6	General Installation	10
<b>6</b>	<b>Electrical Installation</b>	<b>11</b>
6.1	Grid-connected electrical system	11
6.2	Grounding	11
6.3	General installation	13
<b>7</b>	<b>Commission and Maintenance</b>	<b>14</b>
7.1	Blocking diodes and bypass diode	14
7.2	Testing, commissioning and troubleshooting	15

7.3	Maintenance	16
7.4	Testing and replacing bypass diodes	16
<b>8</b>	<b>Disclaimer of liability</b>	<b>17</b>
<b>9</b>	<b>Specifications for TM-series photovoltaic modules under STC</b>	<b>17</b>
9.1	By-pass diodes specifications	18

## 1 General installation

Installing solar photovoltaic systems may require specialized skills and knowledge. Installation should be performed only by qualified persons.

Each module comes with a permanently attached junction box. Tamesol® can provide customers with fitted cables for ease of installation if desired.

The installer should assume the risk of all injury that might occur during installation, including, without limitation, the risk of electric shock.

One individual module may generate DC voltages greater than 30 volts when exposed to direct sunlight. Contact with a DC voltage of 30V or more is potentially hazardous.

When disconnecting wires connected to a photovoltaic module that is exposed to sunlight, an electric arc may result. Such arcs may cause burns, may start fires and may otherwise create problems. Therefore, be extremely careful!

Photovoltaic solar modules change light energy to direct-current electrical energy. They are designed for outdoor use. Modules may be ground mounted, mounted on rooftops, vehicles or boats.

Proper design of support structures is the responsibility of the system designer and installer. Proper use of mounting holes is suggested in a following paragraph.

Do not attempt to disassemble the modules, and do not remove any attached nameplates or components from the modules.

Do not apply paint or adhesive to module top surface.

Do not use mirrors or other magnifiers to artificially concentrate sunlight on the module.

When installing the system, abide with all local, regional and national statutory regulations. Obtain a building permit where necessary. Abide with any local and national regulations when mounting on vehicles or boats.

The modules are qualified for application class A: Hazardous voltage (IEC 61730: higher than 50V DC; EN 61730: higher than 120V), hazardous power applications (higher than 240W) where general contact access is anticipated (Modules qualified for safety through EN IEC 61730-1 and -2 within this application class are considered to meet the requirements for Safety Class II).

The assembly is to be mounted over a fire resistant roof covering rated for the application.

## 2 Safety precaution

Solar modules produce electrical energy when light shines on their front surface. The DC voltage may exceed 30V. If modules are connected in series, the total voltage is equal to the sum of the individual module voltages. If modules are connected in parallel, the total current is equal to the sum of individual module currents. The following points must be observed when handling the solar modules to avoid the risk of fire, sparking and fatal electric shock.

Keep children well away from the system while transporting and installing mechanical and electrical components. Completely cover the module with an opaque material during installation to keep electricity from being generated.

Do not wear metallic rings, watchbands, ear, nose, lip rings or other metallic devices while installing or troubleshooting photovoltaic systems.

Abide with the safety regulations for all other components used in the system, including wiring and cables, connectors, charging regulators, inverters, storage batteries and rechargeable batteries, etc. Use only equipment, connectors, wiring and support frames suitable for a solar electric system.

Always use the same type of module within a particular photovoltaic system.

The electrical characteristics are within 0/+5 Wp of the indicated values of  $I_{sc}$ ,  $V_{oc}$ , and  $P_{max}$  under standard test conditions (irradiance of 1000W/m<sup>2</sup>, AM 1.5 spectrums, and a cell temperature of 25°C (77°F)).

Under normal outdoor conditions the module will produce current and voltages that are different than those listed in the data sheet. Data sheet values are values expected at standard test conditions. The suggested fuse must be used for overcurrent protection. Accordingly, the values of  $I_{sc}$  and  $V_{oc}$  marked on this module should be multiplied by a factor of 1.25 when determining component voltage ratings, conductor ampacity, fuse sizes, and size of controls connected to the PV output. The maximum load on the module must not exceed 5400Pa. To avoid exceeding the maximum load, site-specific live loads such as wind and would be taken into account. Installation shall be in accordance with local standard and conditions.

### 2.1 Warning



Do not insert any electrically conducting materials into the plugs or sockets.



Do not fit solar modules and wiring with wet plugs and sockets.



Make sure to use safety equipment (insulated tools, insulated gloves, etc.) when wiring.

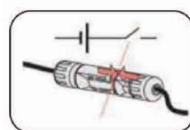

Make sure that you do the connection when the circuitry is cut off. Do not disconnect under load.



Guarantees the clean connectors have not been polluted, and the electrical connection and the mechanical joint is good, to avoid the generation of electric arc effectively.

### 3 Product identification

Each module is fitted with two identical barcodes (one on the laminate under the front glass, the second on the module rear cover) for its unique identification. Each module has a unique serial number with 13.

A nameplate is also affixed on the rear side of each module. This nameplate defines the model type, as well as the main electrical and safety characteristics of the module.

### 4 Unpacking and storing

Utmost attention is required when handling the modules. Below marks will be used for some caution items when unpacking, transporting and storing the modules:



Do not strike and destroy the module.

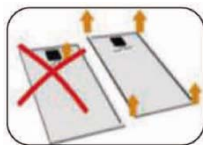

Carry modules with both hands. Do not use the connection socket as a handle; Don't lacerate the frame during handling and installing.



Do not stand on the module.



Do not twist the module.

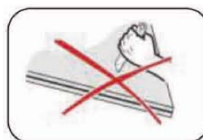

Do not mark on the rear of the module using sharp objects.

## 5 Mechanical Installation

### 5.1 Selecting the location

Select a suitable location for installation of the module.

The module should be facing true south in northern latitudes and true north in southern latitudes for best power production. For detailed information on the best elevation tilt angle for the installation, refer to standard solar photovoltaic installation guides or a reputable solar installer or systems integrator. The module should not be shaded at any time of the daytime.

The modules are to be installed with tilt angle from zero degree to 70 degrees.

### 5.2 Selecting the proper support frame

Always observe the instructions and safety precautions included with the support frames to be used with the modules.

Do not attempt to drill holes in the glass surface of the modules. To do so will void the warranty.

Do not drill additional mounting holes in the frame of the modules. Doing so will void the warranty.

The support module mounting structure must be made of durable, corrosion-resistant and UV-resistant material.

Modules must be securely attached to the mounting structure using all eight (8) mounting points or four (4) mounting points clamping method of mounting system approved by CEC (clean energy council)

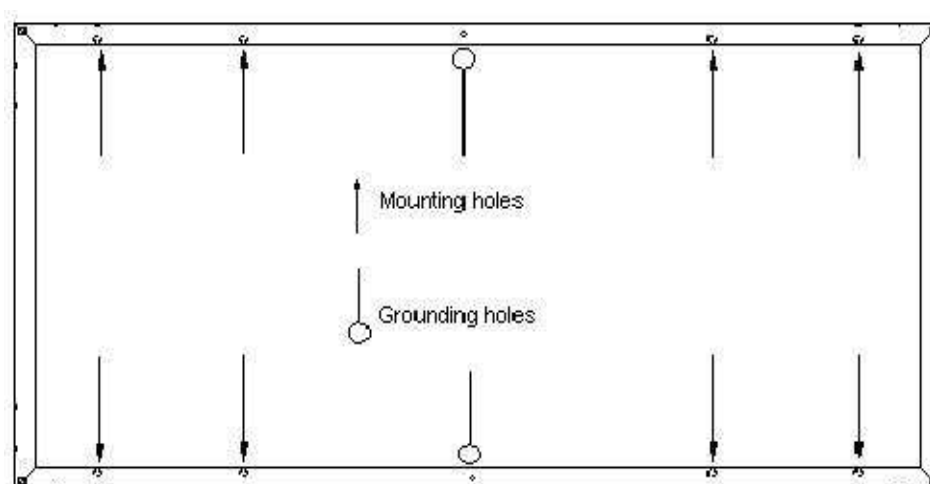

The modules shall be secured with M8 stainless steel or equivalent bolts with washers and nuts. The applied torque is about 8 Newton-meters.

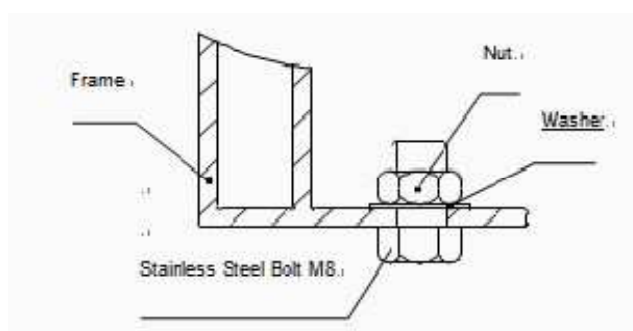

When tightening the nuts to the frame, should be considered that the function of this is to attach the module to the structure. Therefore, be careful the nuts are completely screwed without exercising excessive pressure on the frame as this could cause damage on it. It must be considered that the structure that provides the module frame must not be altered in any

ways as this adversely affect the sealing of the module and cause leaks. This could void the warranty.

A properly installation when fixing the panels on the structure is a separation from the corner of the module with a minimum of 10 cm, less distance is not allowed and it will void the warranty. As you can see below:

Wrong installation:

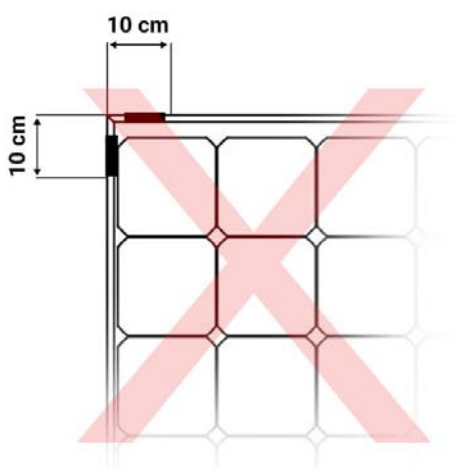

Correct installation:

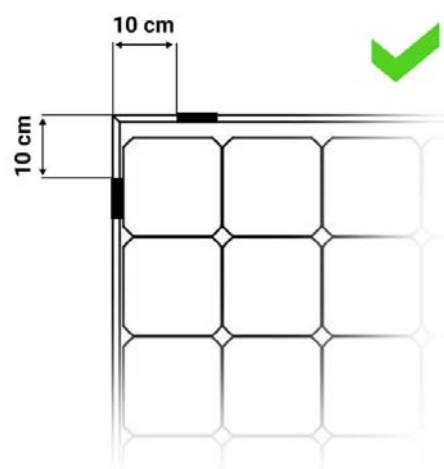

### 5.3 Ground mount

Select the height of the mounting system to prevent the lowest edge of the module from being covered by snow for a long time in winter in areas that experience heavy snowfalls. In addition, assure the lowest portion of the module is placed high enough so that it is not shaded by plants or trees or damaged by sand and stone driven by wind.

### 5.4 Roof mount

When installing a module on a roof or building, ensure that it is securely fastened and cannot fall as a result of wind or snow loads. Provide adequate ventilation under a module for cooling (100mm minimum air space between module and mounting surface).

When installing module on a roof, ensure that the roof construction is suitable. In addition, any roof penetration required to mount the module must be properly sealed to prevent leaks. In some cases, a special support frame may be necessary. The roof installation of solar modules may affect the fireproofing of the house construction. The modules are rated fire Class C, and are suitable for mounting over a class A roof. Do not install modules on a roof or building during strong winds in case of accidents.

## 5.5 Pole mount

When installing a module on a pole, choose a pole and module mounting structure that will withstand anticipated winds for the area.

## 5.6 General Installation

Module mounting must use the pre-drilled mounting holes in the frame. The most common mounting is achieved by mounting the module using the four symmetry points close to the inner side on module frame.

The following stainless steel hardware is in combination with the following model number PV modules.

Module	Mounting hardware configuration			
	Hardware	Material	Size	Number provided
All	Bolt	SS	M8	4
	Nut	SS	M8	4
	Flat Washer	SS	8 mm	8
	Split Washer	SS	8 mm	4

The torque of the M8 bolt is 7.5 N\*m. SS – Stainless Steel.

If excessive wind or snow loads are expected, all eight mounting holes must be used.

Do not lift the module by grasping the module's junction box or electrical leads.

Do not stand or step on module.

Do not drop module or allow objects to fall on module.

To avoid glass breakage, do not place any heavy objects on the module.

Do not set the module down hard on any surface.

Inappropriate transport and installation may break module.

## 6 Electrical Installation

### 6.1 Grid-connected electrical system

The DC electrical energy generated by photovoltaic systems may also be converted to AC and connected to a utility grid system. As local utilities' policies on connecting renewable energy systems to their grids vary from region to region. Consult a qualified system designer or integrator to design such a system. Permits are normally required for installing such a system and the utility must formally approve and inspect such a system before it can be connected to the grid.

### 6.2 Grounding

The module frame must be properly grounded. The grounding wire must be properly fastened to the module frame to assure good electrical contact. Use the recommended type, or an equivalent, connector for this wire.

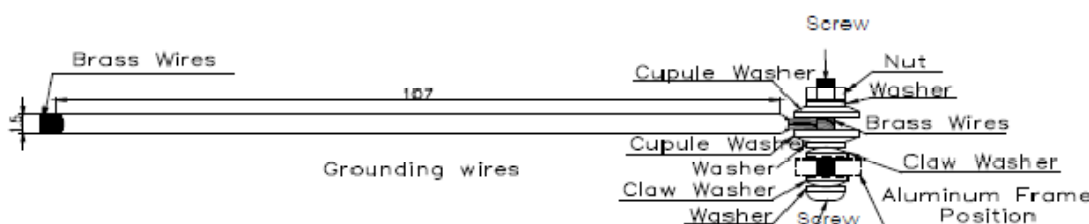

Assembly	Type	Material	Number
Screw	Φ4mm	Stainless steel	1
Nut	Φ4mm	Stainless steel	1
Washer	Φ4mm	Stainless steel	3
Claw Washer	Φ4mm	Stainless steel	2
Cupule Washer	Φ4mm	Stainless steel	2

TAMESOL 240-260P

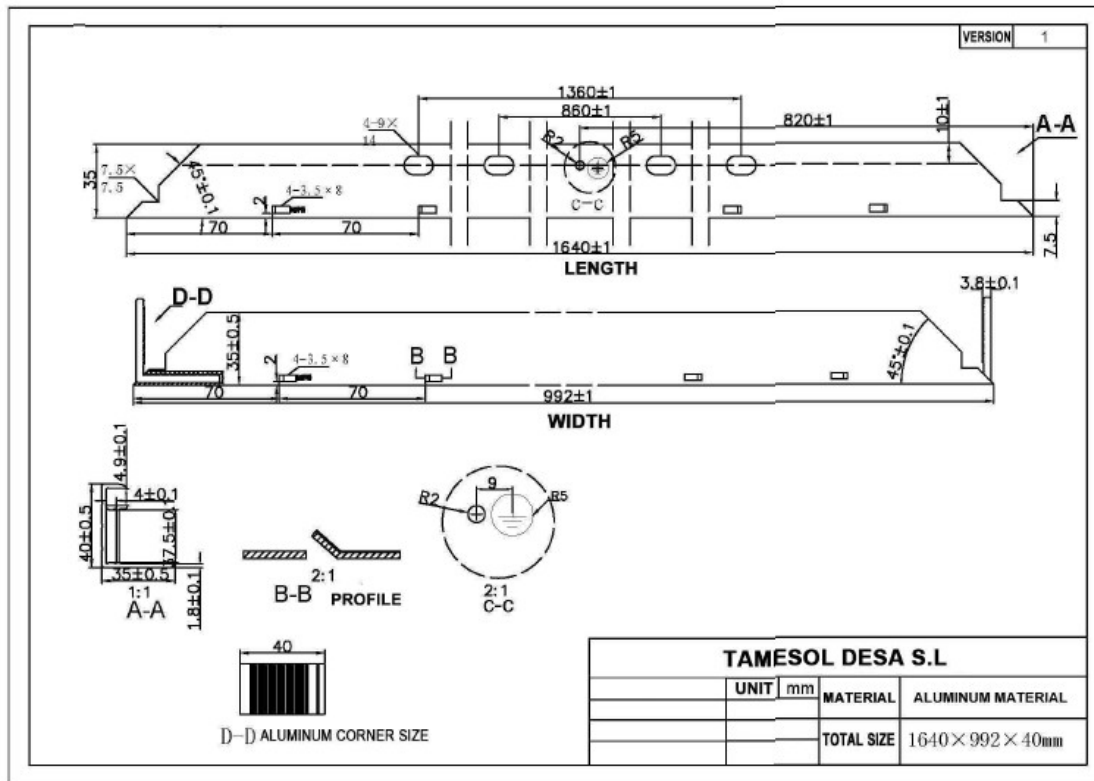

If the support frame is made of metal, the surface of the frame must be electroplated and have excellent conductivity.

The following hardware is required in order to provide a reliable grounding connection to the module frame:

Module	Grounding Clip	
	Manufacturer	Type
All	Tyco Electronics Corp	1954381-2

First strip 16mm insulating jacket from the end of the ground wire (4-14 STR.) carefully to avoid nicking or cutting conductors, insert the wire into the slot of the lug (see the picture), and screw down the slotted screw.

Next, assemble the recommended ILSCO grounding lug to the aluminum frame using stainless steel M3 or M5 screw and hardware as shown below. Note: there are two different size grounding holes, the smaller of which is being phased out.

Further, buildup of hardware for mounting the grounding lug are the same—except for the M3 screw, an added flat washer is mounted directly under the M3 screw head. The star washer is fitted directly under the grounding lug and makes electrical contact by penetrating the anodized

coating of the aluminum frame, The screw assembly is further fitted with a flat washer, then a split lock washer and finally a nut to secure the entire assembly, as shown. Recommended torque of M3 or M5 screw assembly is 0.8NM or 1.5 NM.

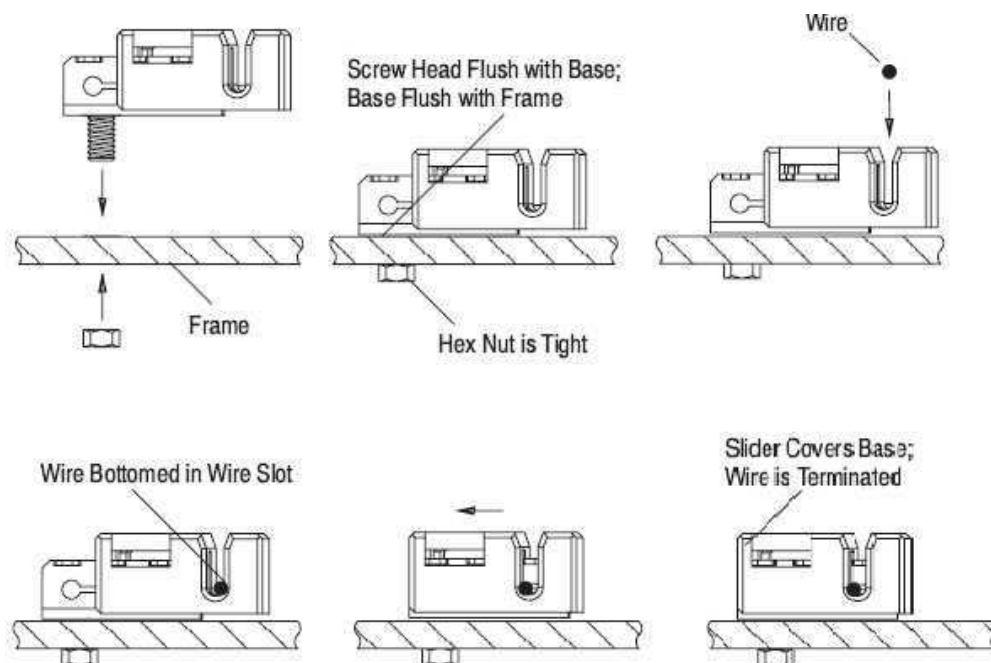

### 6.3 General installation

Typically electrical work for PV systems requires building permits. The installer is responsible to understand the permits and codes that must be obeyed for electrical hook up.

The PV Module has a pair of male and female waterproof connectors. For a series electrical connection, connect positive (+) connector of first PV Module to negative (-) connector of the following Module.

Do not short the positive and the negative. Do not disconnect under load. Be sure connectors have no gap between the insulators. In case there is a gap, a fire and/or an electrical shock may occur.

The installer must size the array wiring so that maximum voltage drop from the module to the inverter is less than 2%.

Do not use modules of different configurations in the same system. Several modules are connected in series and then in parallel to form a PV array, especially for application with a high operation voltage. If modules are connected in series, the total voltage is equal to the sum of individual voltages. All modules must have the same amperage in order to have optimal power output.

For applications requiring high currents, several photovoltaic modules can be connected in parallel; the total current is equal to the sum of individual currents.

Module is supplied with Multicontact connectors (PV-KBT4 and PV-KST4) to use for system electrical connections. Consult rated local wiring regulations to determine system wire size, type, and temperature. For field connections, use minimum 12 AWG copper wires insulated for a minimum of 90 °C.

The cross section area of cable and the capacity of connector must be selected to suit the maximum system short circuit current, otherwise the cable and connector will be overheated under large current.

Module overcurrent protection, rated for DC use. Fuse ratings are as shown the enclosed tables of this Installation Manual.

The junction box is fitted with a breather port. The breather port must be mounted facing down and cannot be exposed to rain. Therefore, the junction box must be on the higher side of the module when it is mounted.

## 7 Commission and Maintenance

Tamesol® recommends that all work in commissioning and maintenance of a system must be performed by a qualified solar PV technician.

### 7.1 Blocking diodes and bypass diode

Blocking diodes prevent current flowing from the battery to the module when no electricity is being generated. It is recommended to use blocking diodes when a charging regulator is not used. Your specialist dealer can advise you with regards to suitable types.

In systems with more than two modules in series, high reverse current can flow through cells that are shaded partially or outright when part of a module is shaded and the rest is exposed to the sun. These currents can cause the affected cells to get very hot and could even damage the module. To protect module from such high reverse currents, by-pass diodes are used in module. All modules rated greater than 55 Watt have bypass diode already integrated in the junction box. In the unlikely event of diode failure, Tamesol® recommends a qualified service technician be employed to determine if diodes have failed and to make replacement.

Protect yourself against electricity shocks while commissioning and maintaining the solar power system.

## 7.2 Testing, commissioning and troubleshooting

Test all electrical and electronic components of your system before commissioning it. Follow the instructions in the guides supplied with the components and equipment.

TESTING MODULES CONNECTED IN SERIES BEFORE THEY ARE CONNECTED TO SYSTEM.

- To determine Voc and Isc in the following tests, the module(s) must be exposed to the sun and not connected to a load. Observe personal safety when making these measurements.
- Check the open-circuit voltage (Voc) of every series module using a digital multimeter (Fluke 170 series are recommended). The measured system Voc should correspond to the sum of the Vocs of the individual module. You will find the rated voltage in the technical specifications of the type of the module used and in the tables at the end of this Installation Guide. If the measured value is significantly lower than the expected value, proceed as described under "Troubleshooting an excessively low voltage".
- Determine the short-circuit current (Isc) of every series circuit. It can be measured directly by connecting the digital multimeter connected in the two terminals of series circuit or module, Attention, the rated scale of the ammeter or the rated current of load should more than 1.25 times than the rated short-circuit current of series module. You will find the rated current in the technical specifications of the type of module used. The measured value can vary significantly, depending on weather conditions, the time of day and shading of the module.

### TROUBLESHOOTING LOW VOLTAGES

To identify the commonly low voltage and excessively low voltage, the commonly how voltage mentioned here is the decrease of open-circuit voltage of the module, which is caused by the temperature rising of solar cells or lower irradiance. Excessively low voltage is typically caused by improper connections at the terminals or defective bypass diodes.

First, check all wiring connections to make sure it is not open-circuit or is not connection well.

- Check the open-circuit voltage of each module:
- Fully cover the modules with an opaque material.
- Disconnect the wiring at both terminals of the modules.
- Remove the opaque material from the module to be checked and measure the open-circuit voltage at its terminals.
- If the measured voltage is only half of the rated, this indicates a defective bypass diode. Refer to 'Testing and replacing bypass diodes'.
- In the case of not very low irradiance, if the voltage across the terminals differs from the rated value by more than 5 percent, this indicates a bad electrical connection.

## 7.3 Maintenance

Tamesol® recommends the following maintenance in order to ensure optimum performance of the module:

- Clean the glass surface of the module as necessary. Always use water and a soft sponge or cloth for cleaning. A mild, non-abrasive cleaning agent can be used to remove stubborn dirt.
- Check the electrical and mechanical connections every six months to verify that they are clean, secure and undamaged.
- If any problem arises, have them investigated by a competent specialist. Observe the maintenance instructions for all components used in the system, such as support frames, charging regulators, inverters, batteries, etc.

## 7.4 Testing and replacing bypass diodes

Removing the bypass diodes should be done only by a competent PV technician and after the module has been disconnected from the system.

- Place module face down on a soft, flat surface. Insert a 3mm flat screwdriver into the slot on the junction box cover. (The cover has a sign of screwdriver). Gently pull up the four slots until the cover has been opened.
- Insert the 3mm flat screwdriver into a hole alongside of diode and near one mounting hole of the diode, pry the screwdriver in the opposite direction of diode and gently pull the diode up until the lead comes free. Do the same in the other mounting hole of the diode, and repeat until the diode is free.
- Note the orientations of the polarity markings on the diodes.
- Check the resistance of the diodes by using the digital multimeter's ohms scale. Resistance should be low in one direction, then when leads are reversed on the diode's terminals the resistance should be high, as illustrated in the two pictures below. If a diode has a low resistance in both directions, it is probably shorted. If it has high resistance in both directions it is probably open. In either case it should be replaced.
- Replace a defective diode with a diode of the same type, and ensure that its polarity marking is oriented the same way as the original diode.
- Finally, check the open-circuit voltage ( $V_{oc}$ ) of the module, as described previously and replace both covers.

## 8 Disclaimer of liability

Because the use of this manual and the conditions or methods of installation, operation, use and maintenance of photovoltaic (PV) product are beyond Tamesol® control, Tamesol® does not accept responsibility and expressly disclaims liability for loss, damage, or expense arising out of or in any way connected with such installation, operation, use or maintenance.

No responsibility is assumed by Tamesol® for any infringement of patents or other rights of third parties, which may result from use of the PV product. No license is granted by implication or otherwise under any patent or patent rights.

The information in this manual is based on Tamesol®'s knowledge and experience and is believed to be reliable; but such information including product specification (without limitations) and suggestions do not constitute a warranty, expresses or implied. Tamesol® reserves the right to change the manual, the PV produce, the specifications, or product information sheets without prior notice.

## 9 Specifications for TM-series photovoltaic modules under STC

MODEL	Nominal Maximum Power (Pmax)	Optimum Operating Voltage (Vmp)	Optimum Operating Current (Imp)	Open Circuit Voltage (Voc)	Short Circuit Current (Isc)	Maximum system voltage	Max. Series fuse rating
TM-M660255	255W	31,37V	8,45A	38,46V	9,13A	1000V	15A
TM-M672305	305W	37,34V	8,17A	46,30V	8,67A		
TM-P660240	240W	30,16V	7,96A	36,72V	8,72A	1000V	15A
TM-P660245	245W	30,18V	8,14A	36,87V	8,76A		
TM-P660250	250W	30,38V	8,23A	36,97V	8,99A		
TM-P660255	255W	30,46V	8,37A	37,01V	9,07A		
TM-P660260	260W	30,56V	8,51A	37,22V	9,23A		
TM-P672300	300W	36,19V	8,29A	45,67V	8,74A		

## 9.1 By-pass diodes specifications

Module series	Number of bypass diodes	Number of cells by diodes	Diode ratings voltage	Diode ratings current
TM-M660	3	20	$\geq 40V$	$\geq 15A$
TM-M672	3	24	$\geq 40V$	$\geq 15A$
TM-P660	3	20	$\geq 40V$	$\geq 15A$
TM-P672	3	24	$\geq 40V$	$\geq 15A$

Diode configurations as below:

