

PLAYGROUND
SPIELPLATZ
LEIKKITELINE

PLAC ZABAW
AIRE DE JEUX
KLÄTTERSTÄLLNING

(349 x 284 x h188cm)

003_06480_08122020

BAXY

INSTALLATION INSTRUCTIONS
MONTAGEANLEITUNG
ASENNUSOHJEET

INSTRUKCJA MONTAŻU
GUIDE D'INSTALLATION
MONTERINGSANVISNINGAR

Warranty period - 2 years from purchase date
Garantiezeit - 2 Jahre ab Kaufdatum
Takuu-aika - 2 vuotta ostopäivästä

Okres gwarancji - 2 lata od momentu zakupu towaru
Période de garantie - 2 ans à compter de l'achat
Garantiaperiod - 2 år från inköpsdatum



CE
EN - 71

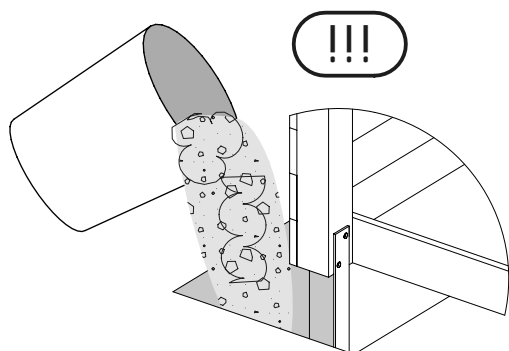
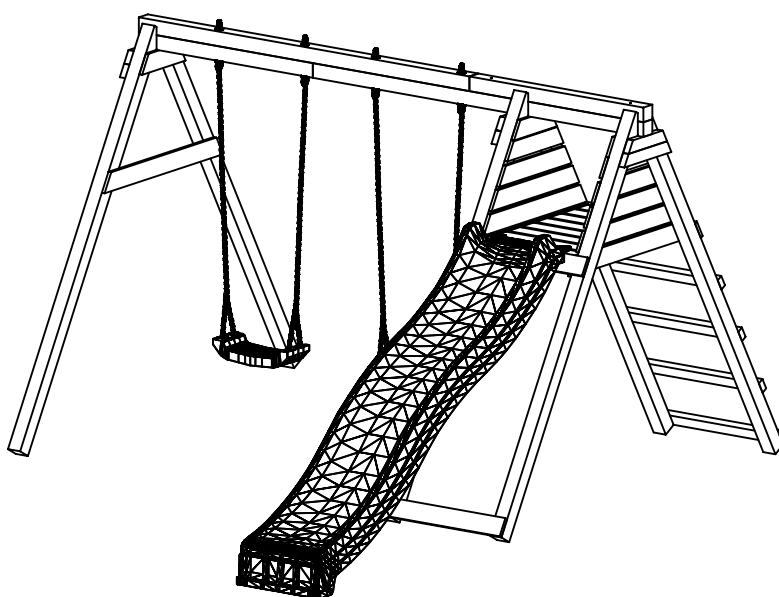

WARNINGS!

Only for home use.
Dedicated for external use only.
Not suitable for children under 3 years old.
Risk of falling down and/or hitting.
Maximum user weight is up to 50 kg.
Maximum number of users staying on the playground at the same time: 6.

OSTRZEŻENIA!

Tylko do użytku domowego.
Przeznaczony do użytku na zewnątrz.
Nie przeznaczony dla dzieci poniżej 3 roku życia.
Niebezpieczeństwo upadku i/lub uderzenia.
Maksymalna waga użytkownika to 50 kg.
Maksymalna liczba użytkowników przebywających na placu zabaw w tym samym czasie: 6.

VAROITUKSET

Vain kotitalouskäyttöön.
Tarkoitettu vain ulkokäyttöön.
Ei soveltu alle 3-vuotiaille lapsille.
Putoamis- ja/tai loukkaantumisaara.
Käyttäjän enimmäispaino on 50 kg.
Samanaikaisten leikkitelineen käyttäjien enimmäismäärä: 6.

ACHTUNG!

Nur für den privaten, häuslichen Bereich.
Ausschließlich für die Verwendung im Freien.
Nicht geeignet für Kinder unter 3 Jahren.
Stolper- und / oder Sturzgefahr
Höchstgewicht pro Einzelkind beträgt 50 kg
Der Aufenthalt auf diesem Spielturn ist max. : 6. Kindern gleichzeitig erlaubt.

AVERTISSEMENT!

Aire exclusivement destinée à un usage privé.
Aire exclusivement destinée à un usage en extérieur.
Prévue pour les enfants de plus de 3 ans.
Danger de chute ou de choc.
Poids maximal d'un utilisateur : 50 kg.
Nombre maximal d'utilisateurs présents en même temps sur la même aire de jeux: 6.

VARNINGAR

Endast för hemmabruk.
Endast avsedd för användning ute.
Ej lämplig för barn under 3 år.
Risk för att falla ner och/eller slå sig.
Max användarvikt är 50 kg.
Maximalt antal samtidiga användare på klätterställningen: 6.

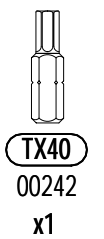
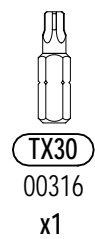
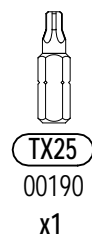
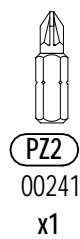
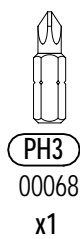
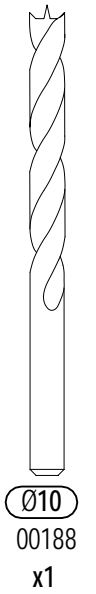
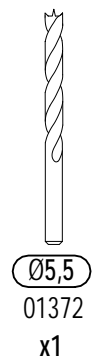
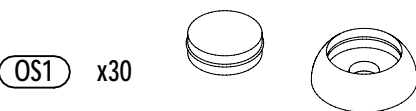
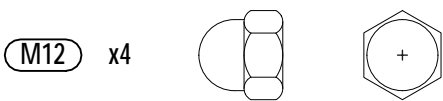
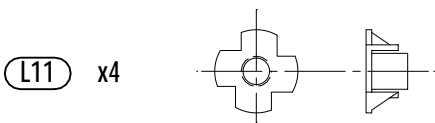
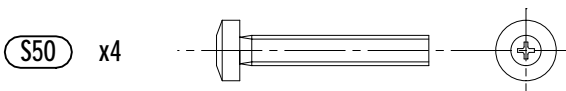
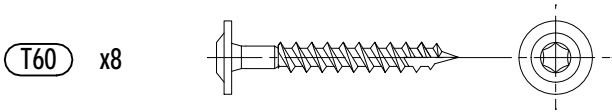
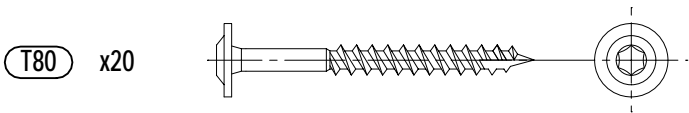
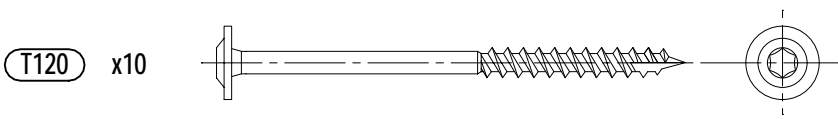
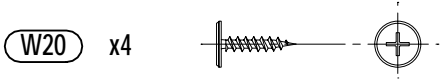
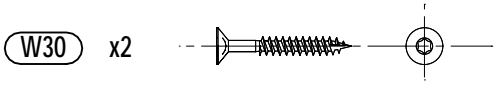
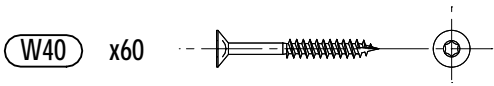
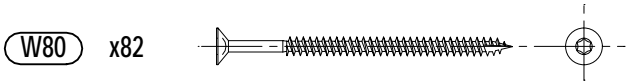

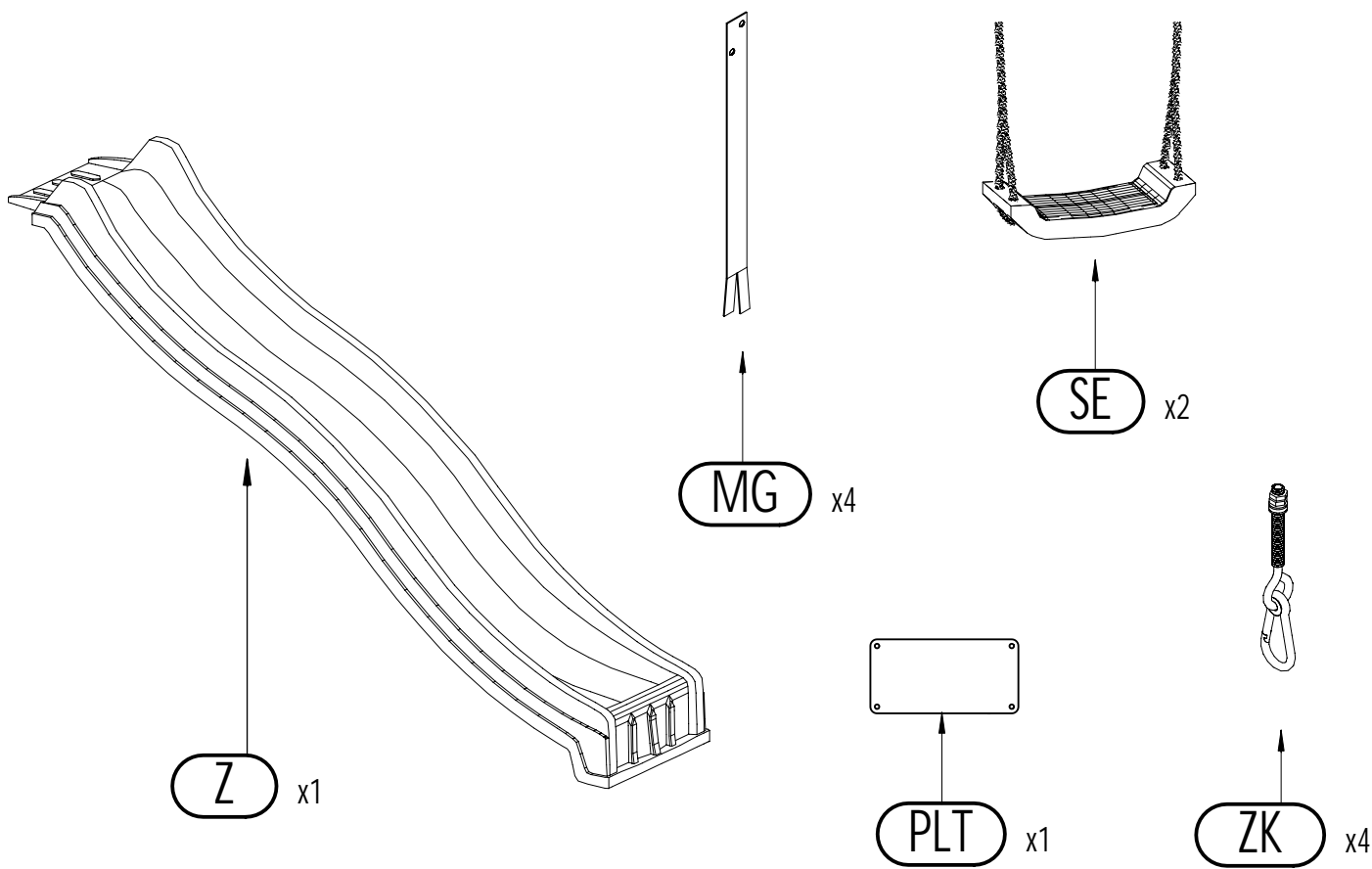
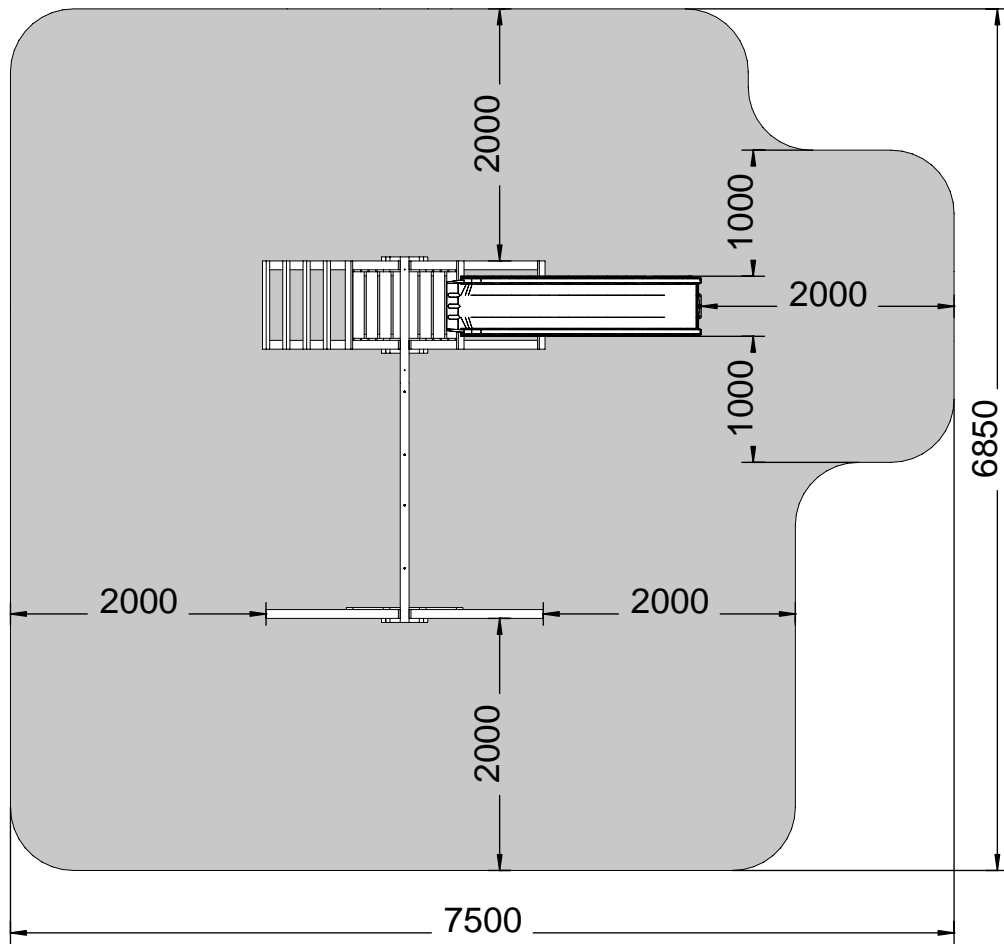

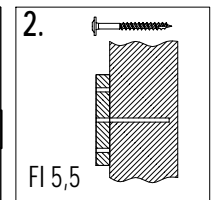
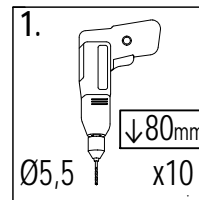
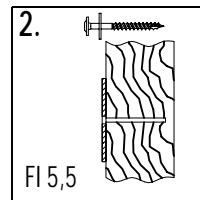
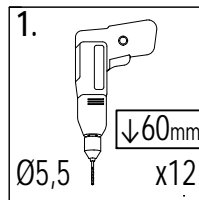
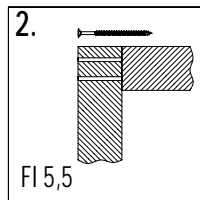
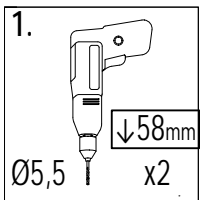
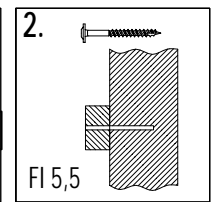
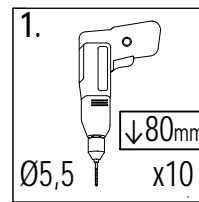
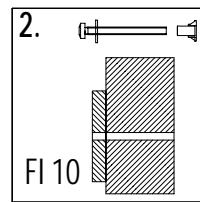
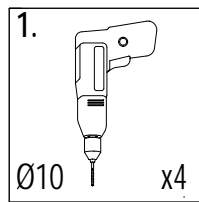
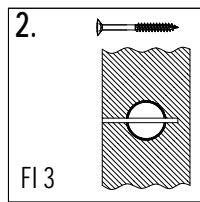
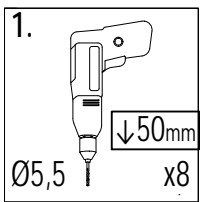
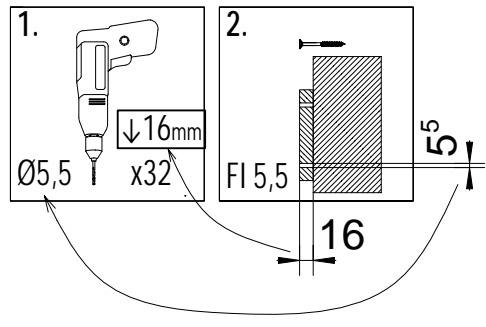
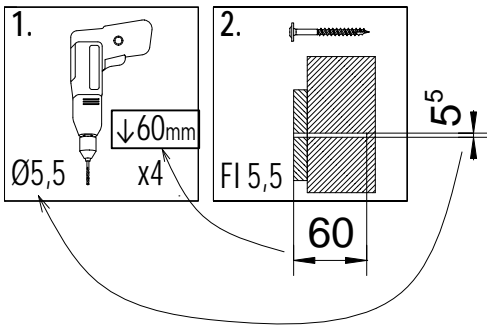
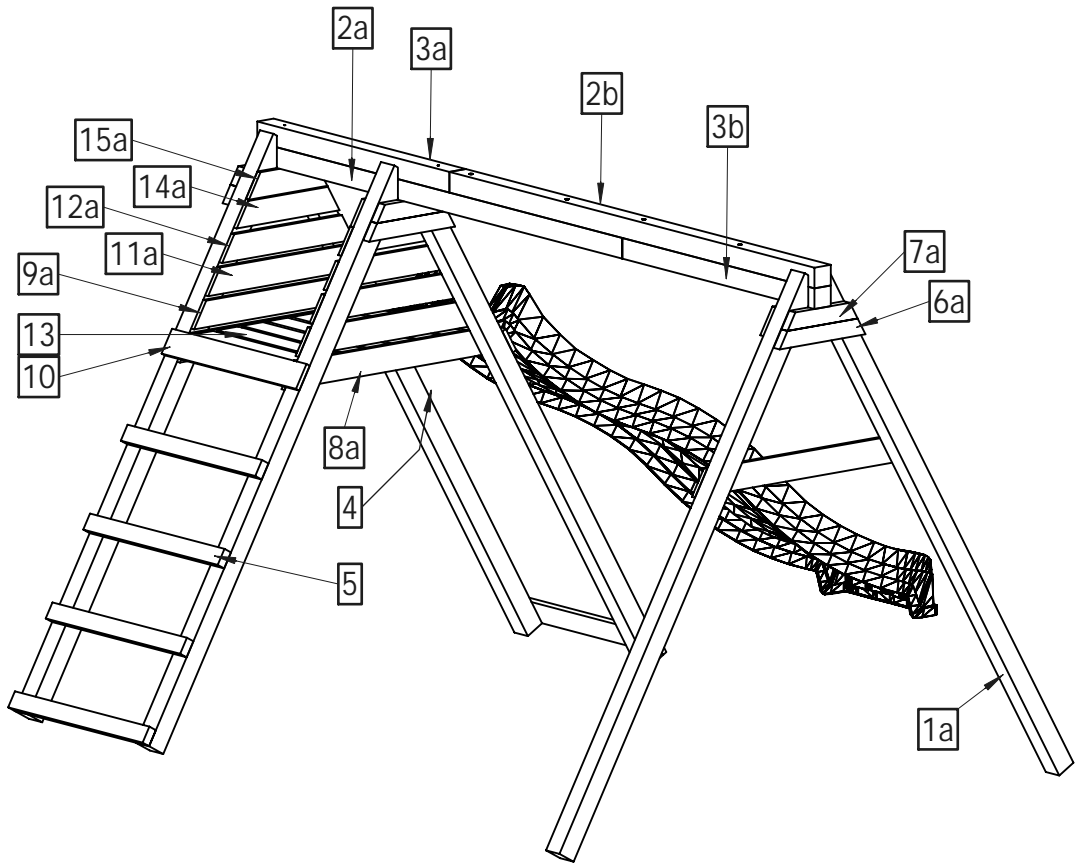

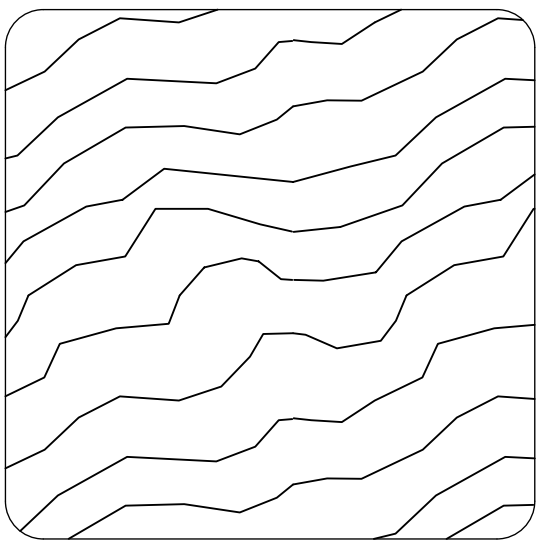

7,0 x 7,0 cm

Lp.	Wymiary [mm]	szt.
1	70x70x2100mm	6
2a	70x70x1900mm	1
2b	70x70x1900mm	1
3a	70x70x1000mm	1
3b	70x70x1000mm	1

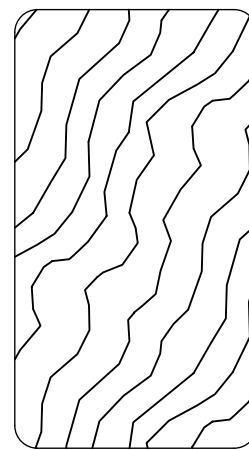

3,2 x 5,8 cm

Lp.	Wymiary [mm]	szt.
4	32x58x840mm	2
5	32x58x700mm	4
6a	32x58x367mm	3
7a	32x58x300mm	3



1,6 x 9,0 cm

Lp.	Wymiary [mm]	szt.
8a	16x90x925mm	3
9a	16x90x805mm	2
10	16x90x700mm	3
11a	16x90x685mm	2
12a	16x90x565mm	2
13	16x90x528mm	8
14a	16x90x440mm	2
15a	16x90x340mm	3

1a

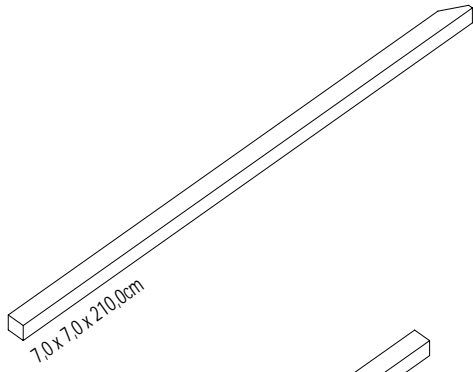

2a

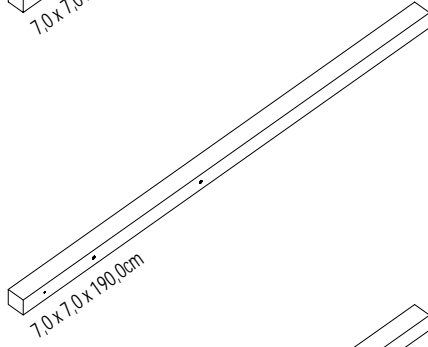

2b

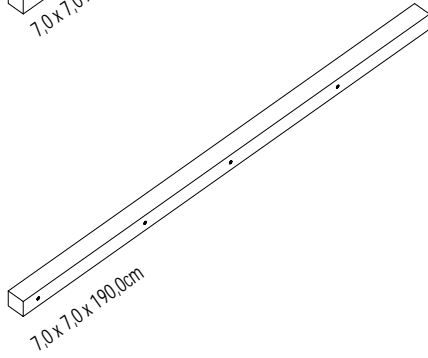

3a

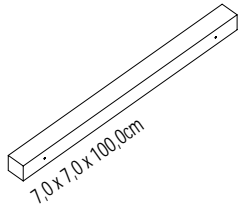

3b

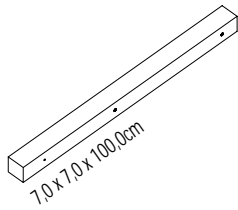

4

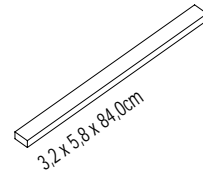

5

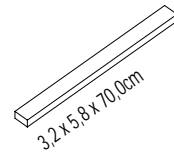

6a

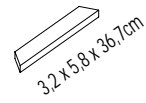

7a

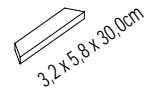

8a

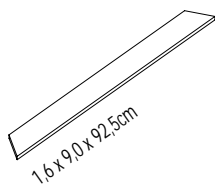

13

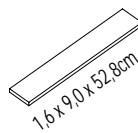

9a

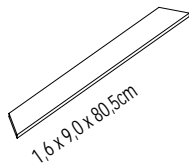

14a

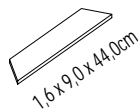

10

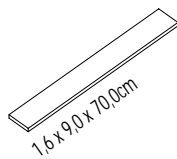

15a

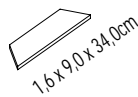

11a

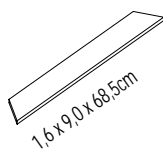

12a

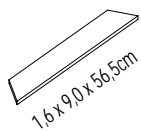

01

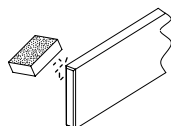
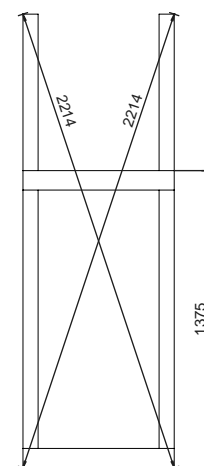
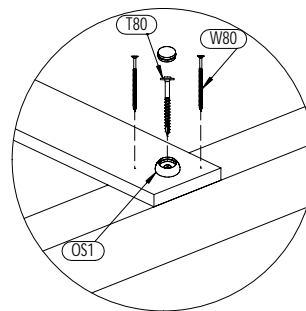
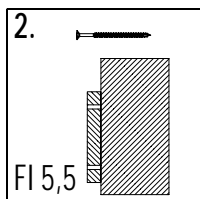
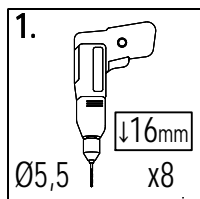
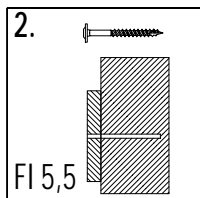
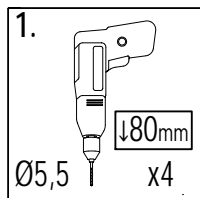

10 1,6x9,0x70,0cm

x2

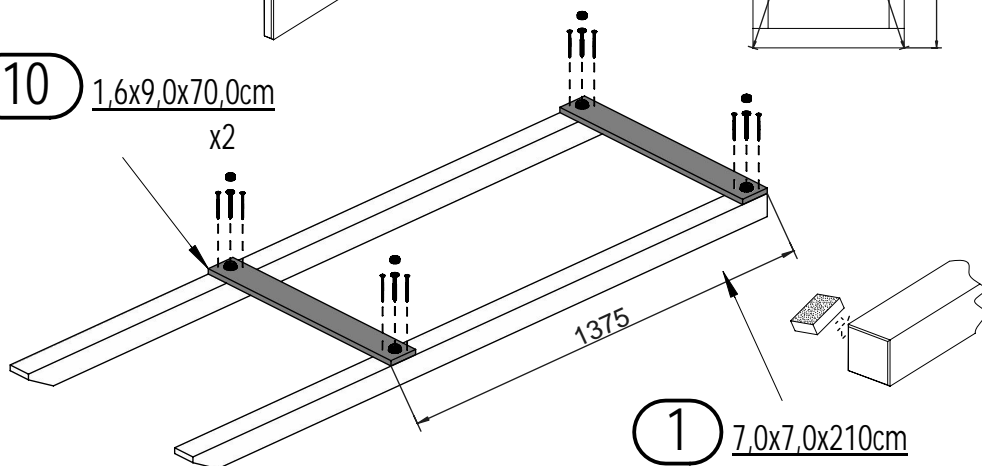

1 7,0x7,0x210cm

x2

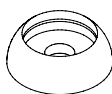

OS1 x4



W80 x8

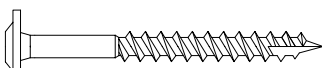

T80 x4

02

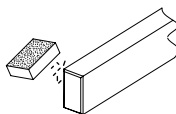
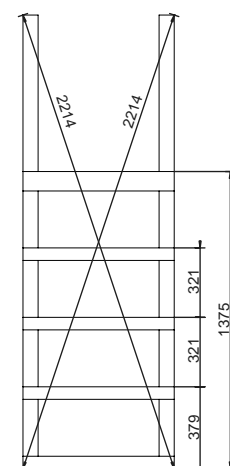
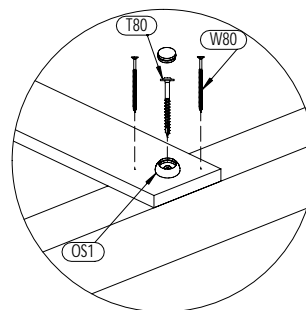
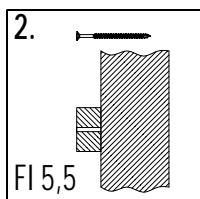
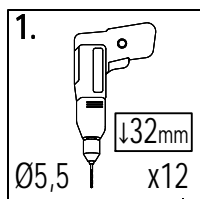
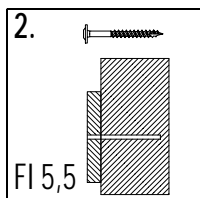
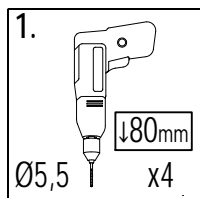

5 3,2x5,8x70,0cm

x4

10 1,6x9,0x70,0cm

x1

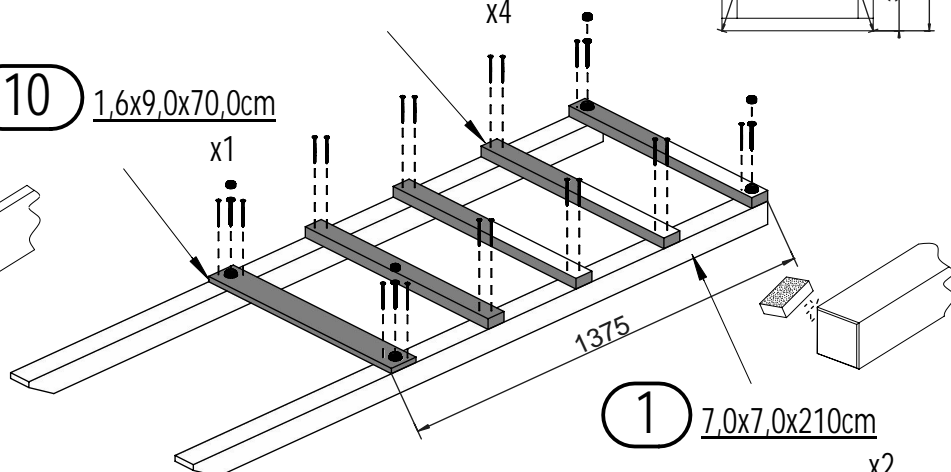

1 7,0x7,0x210cm

x2

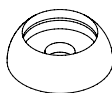

OS1 x4



W80 x18

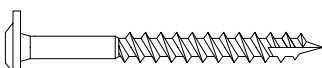

T80 x4

8

Zgodnie z normą PN-EN 71 stosuj zalecenia producenta odnośnie odległości oraz metody mocowania poszczególnych elementów
In compliance with the standard PN-EN 71, apply guidelines of the producer in relation to distances and methods of fastening individual elements

BAXY

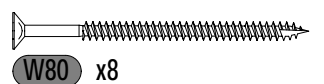
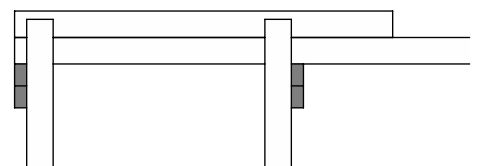
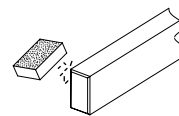
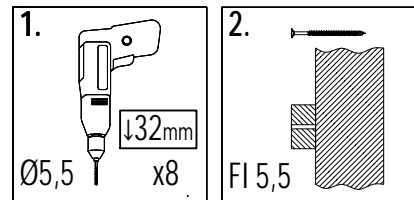
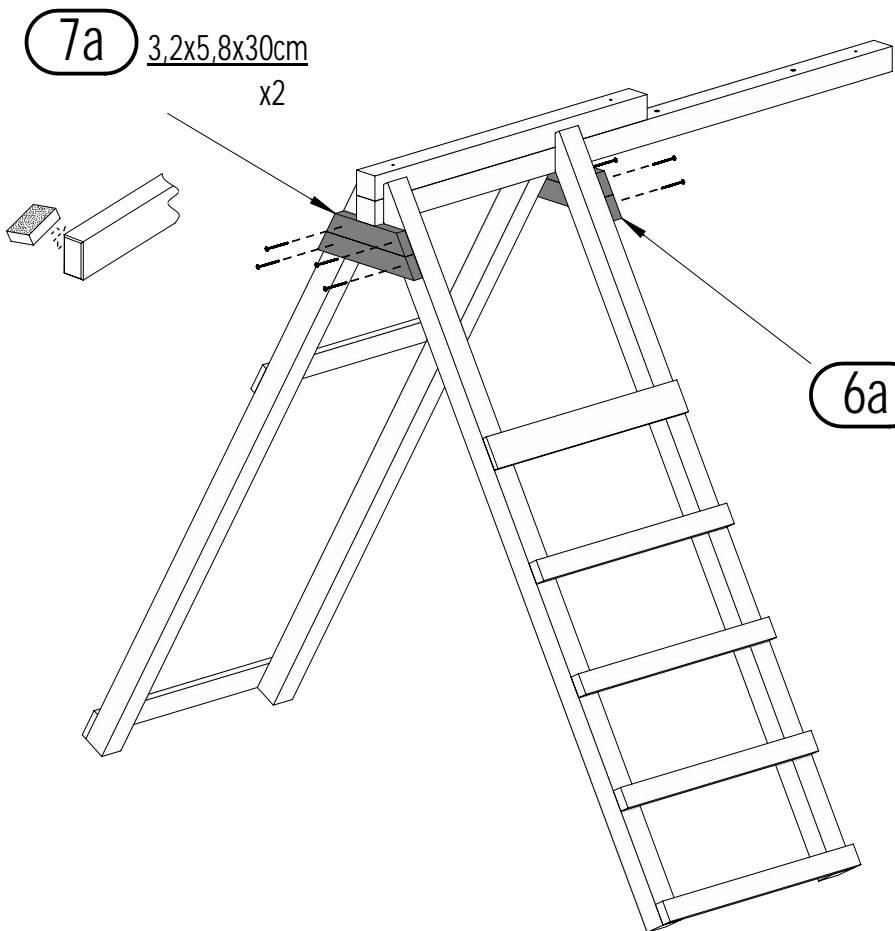
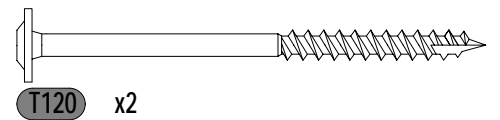
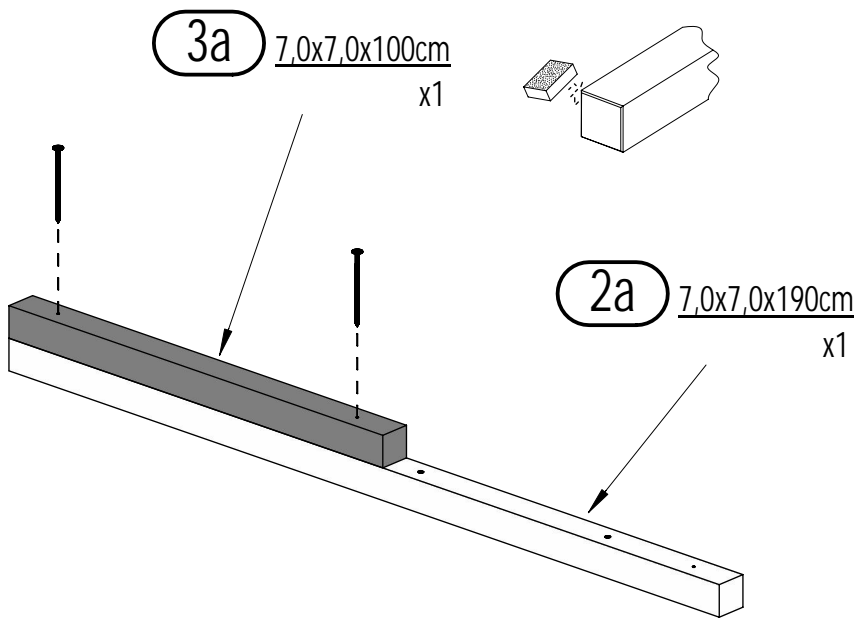

05

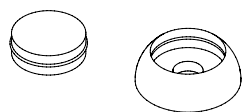
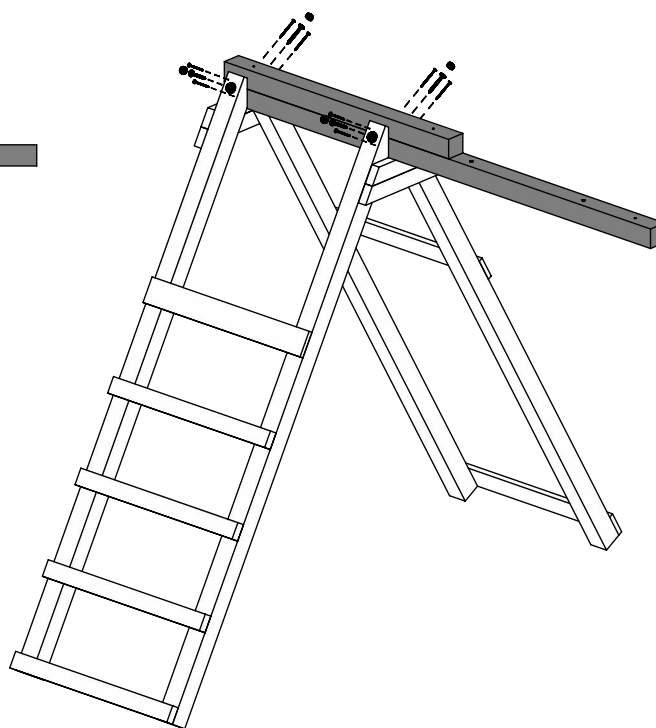
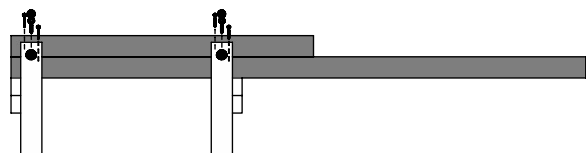
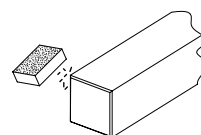
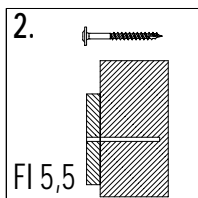
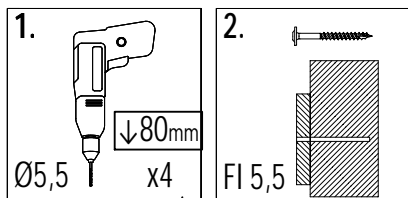

OS1 x4

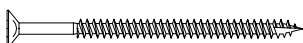

W80 x8

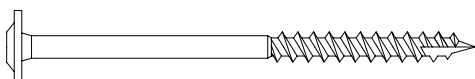

T120 x4

06

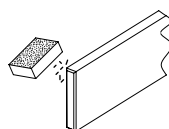
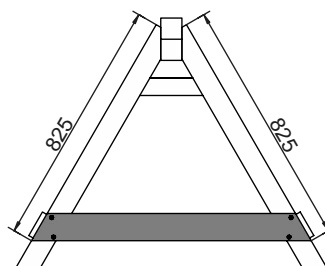
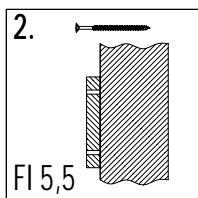
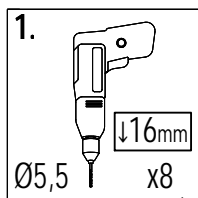

8a 1,6x9,0x92,5cm
x2

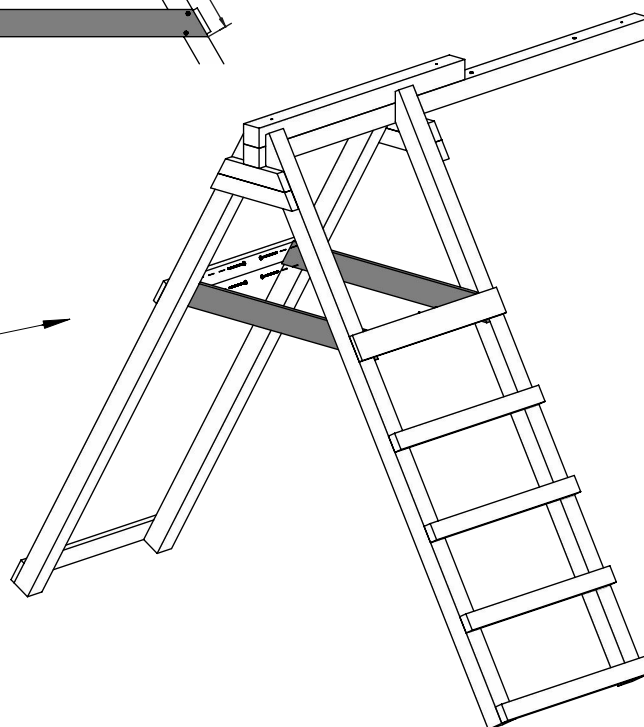

W80 x8

10

Zgodnie z normą PN-EN 71 stosuj zalecenia producenta odnośnie odległości oraz metody mocowania poszczególnych elementów
 In compliance with the standard PN-EN 71, apply guidelines of the producer in relation to distances and methods of fastening individual elements

BAXY

4 3,2x5,8x84,0cm x2

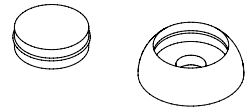
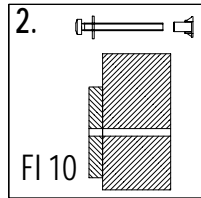
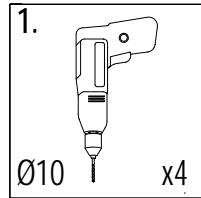
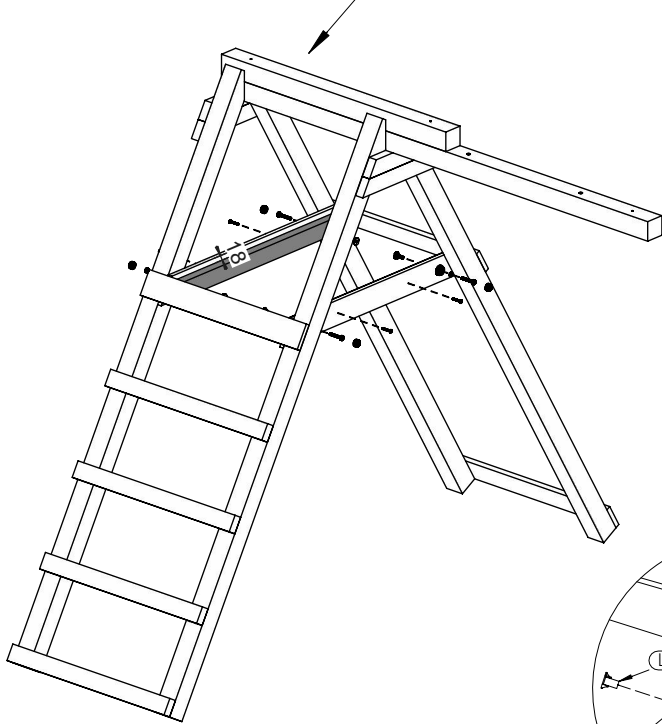

OS1 x4

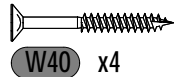

W40 x4

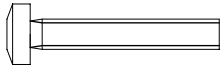

S50 x4



P17 x4



L11 x4

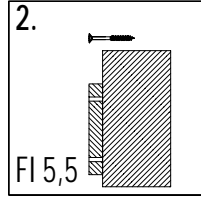
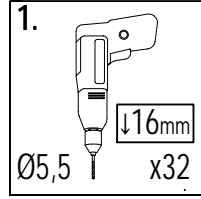
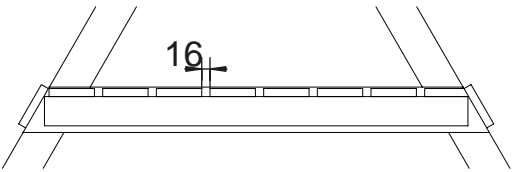
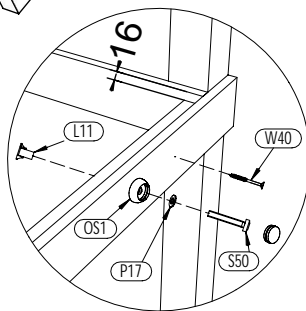

13 1,6x9,0x52,8cm x8

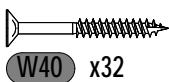
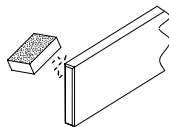

W40 x32

Zgodne z normą PN-EN 71 stosuj zalecenia producenta odnośnie odległości oraz metody mocowania poszczególnych elementów
In compliance with the standard PN-EN 71, apply guidelines of the producer in relation to distances and methods of fastening individual elements

09

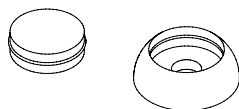
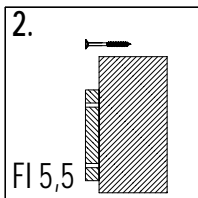
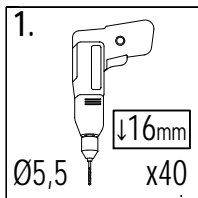

OS1 x8

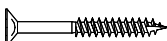

W40 x24



W80 x16

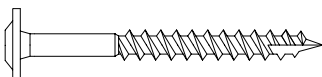

T80 x8

15a 1,6x9,0x34,0cm
x2

14a 1,6x9,0x44,0cm
x2

12a 1,6x9,0x56,5cm
x2

11a 1,6x9,0x68,5cm
x2

9a 1,6x9,0x80,5cm
x2

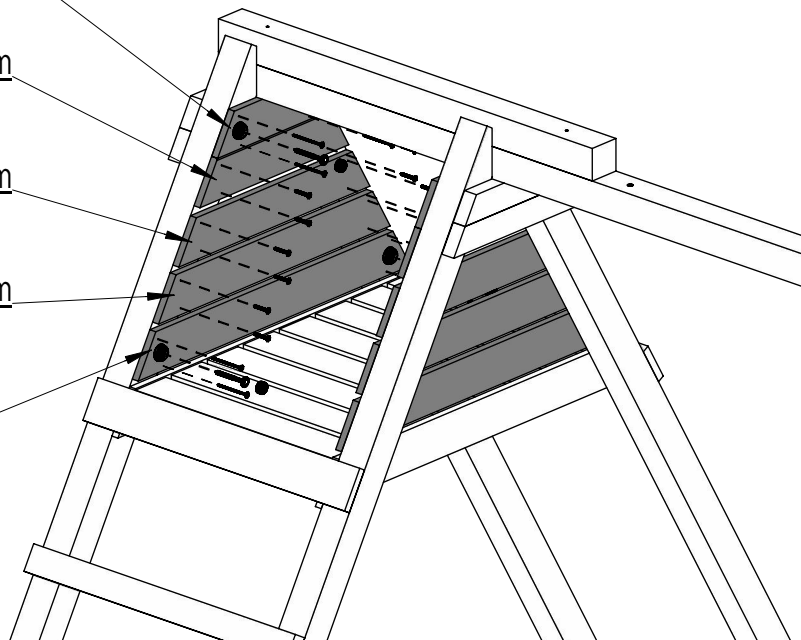
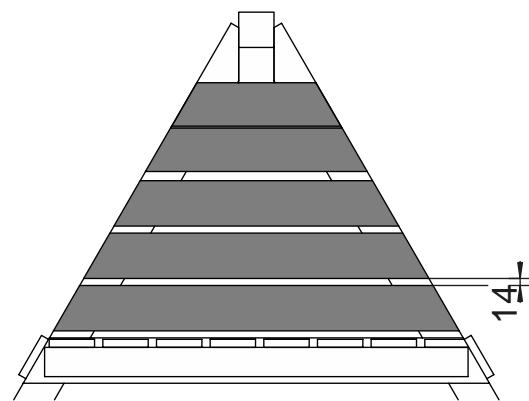
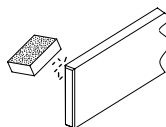

10

ZK x2



2b 7,0x7,0x190cm
x1

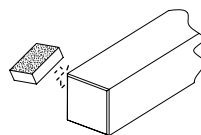

3b 7,0x7,0x100cm
x1

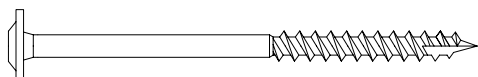
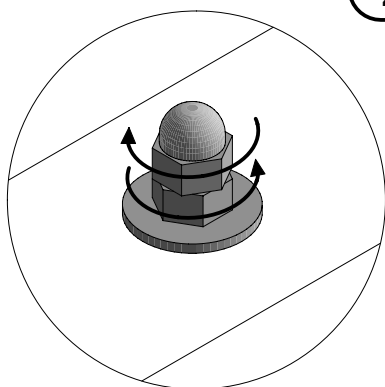

T120 x1

12

Zgodnie z normą PN-EN 71 stosuj zalecenia producenta odnośnie odległości oraz metody mocowania poszczególnych elementów
In compliance with the standard PN-EN 71, apply guidelines of the producer in relation to distances and methods of fastening individual elements

BAXY

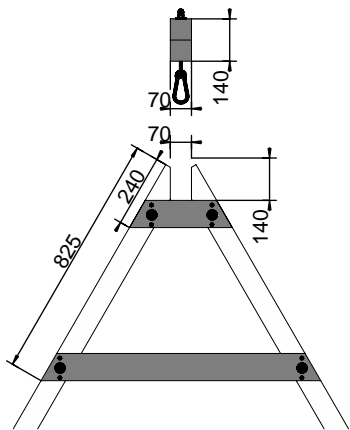

1 7,0x7,0x210cm x2

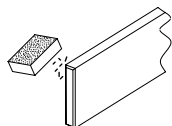
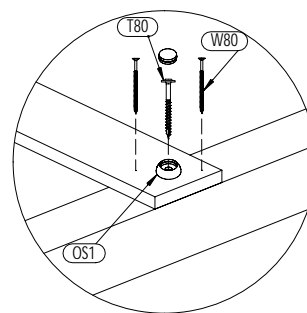
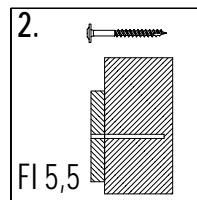
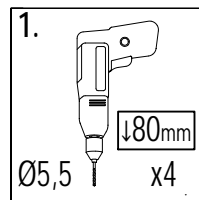

8a 1,6x9,0x92,5cm x1

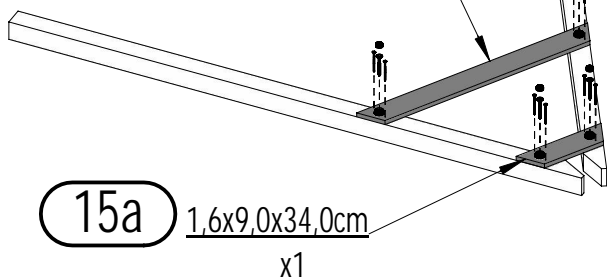

15a 1,6x9,0x34,0cm x1

- OS1 x4
- W80 x8
- T80 x4

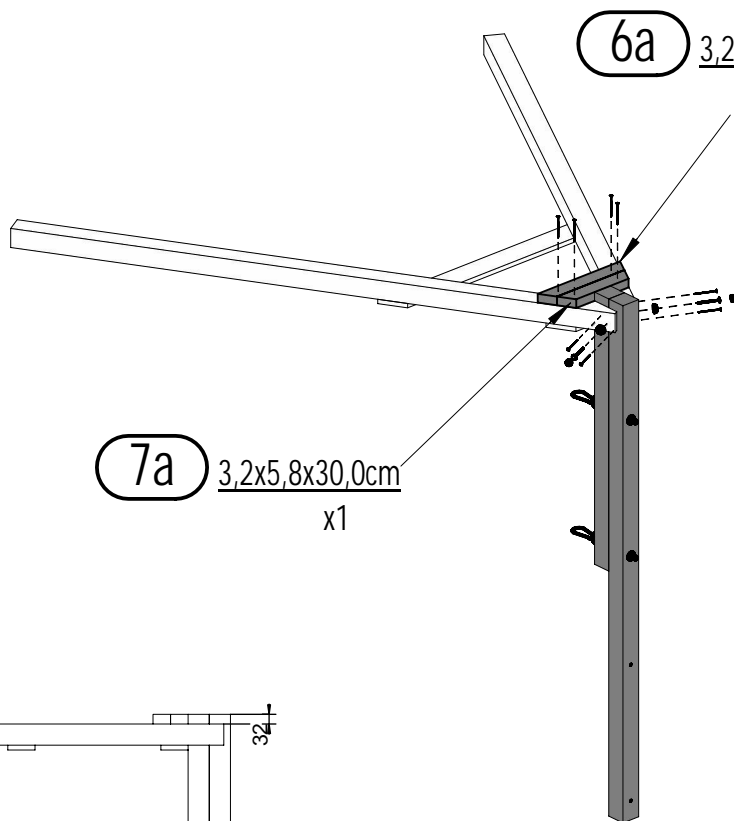

6a 3,2x5,8x36,7cm x1

7a 3,2x5,8x30,0cm x1

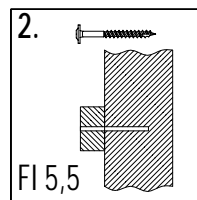
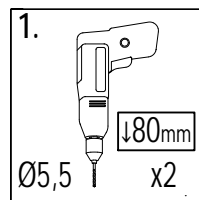

- OS1 x2
- W80 x8
- T120 x2

13

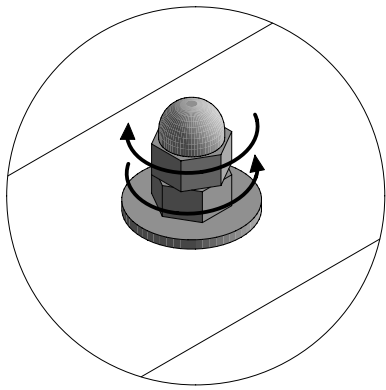

ZK x2

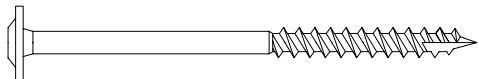
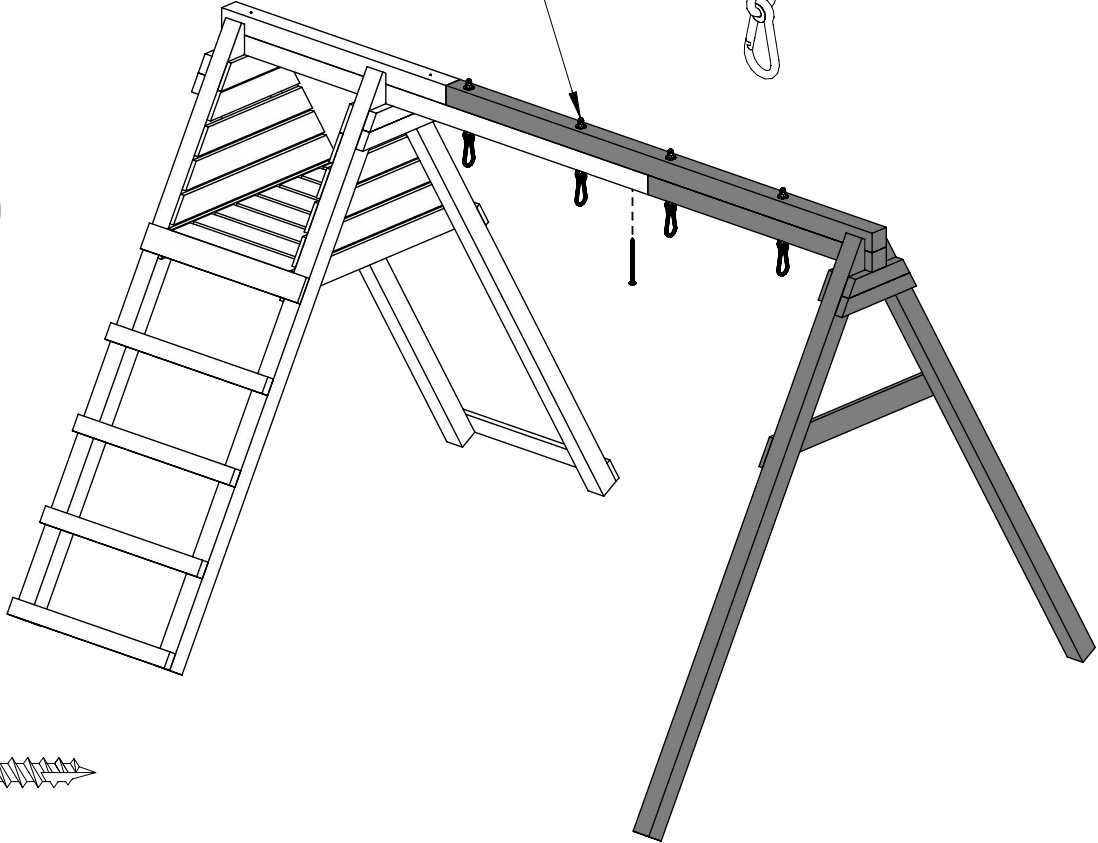

T120 x1

14

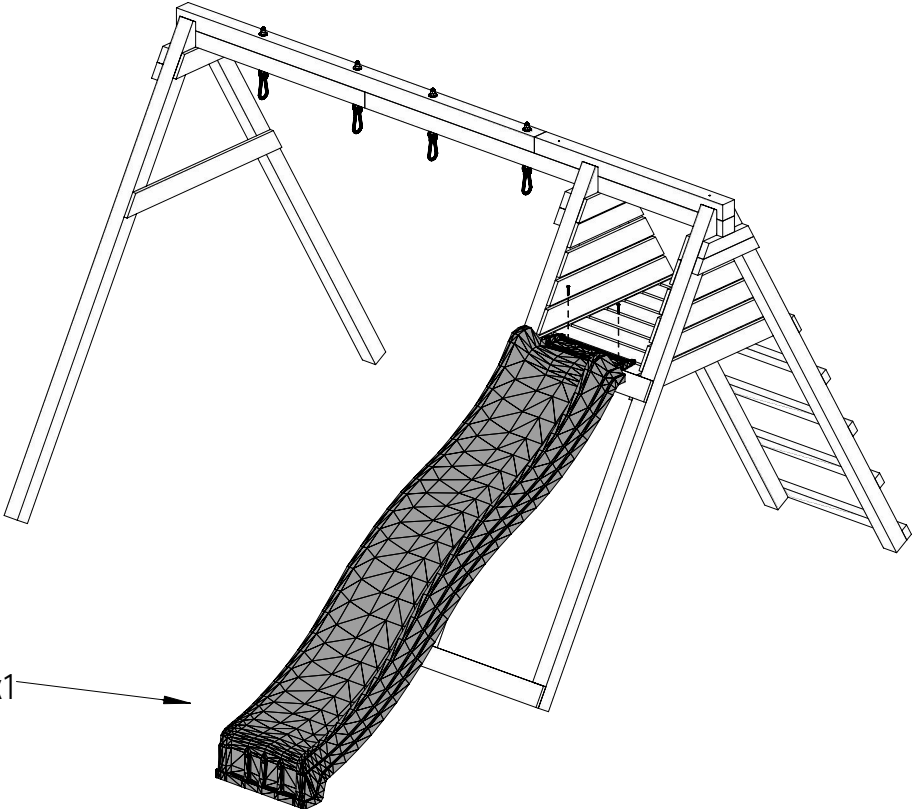

Z x1

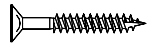

W30 x2

14

Zgodne z normą PN-EN 71 stosuj zalecenia producenta odnośnie odległości oraz metody mocowania poszczególnych elementów
 In compliance with the standard PN-EN 71, apply guidelines of the producer in relation to distances and methods of fastening individual elements

BAXY

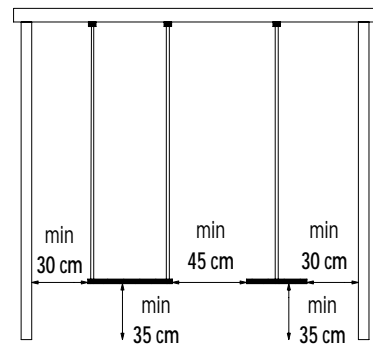
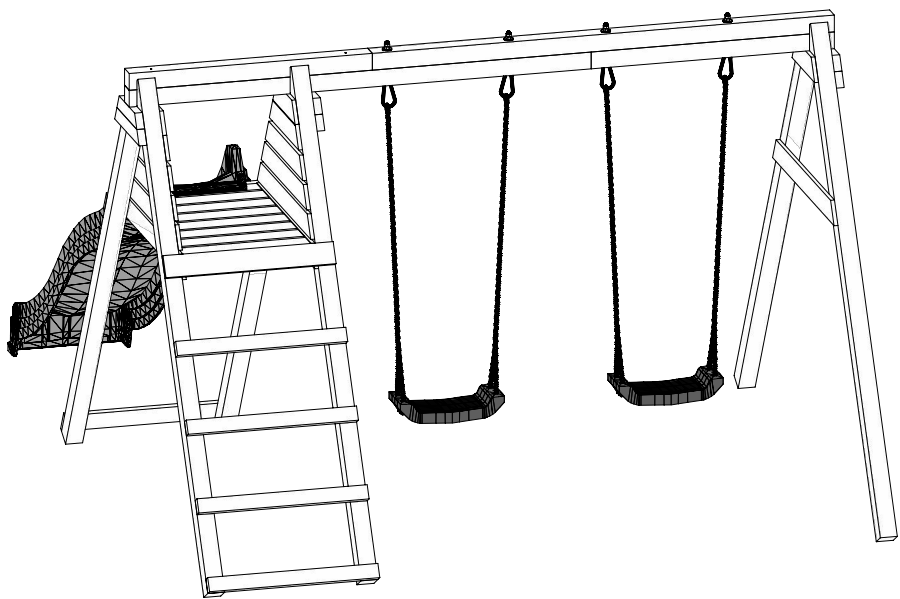

SF x2

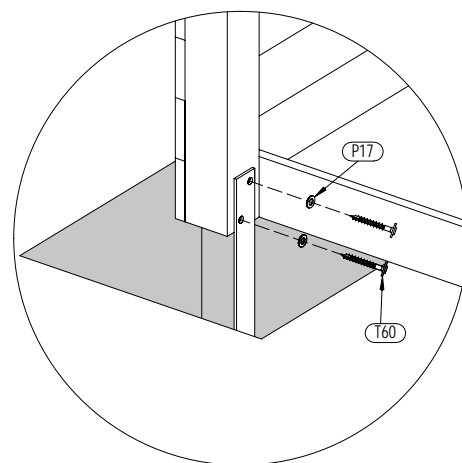
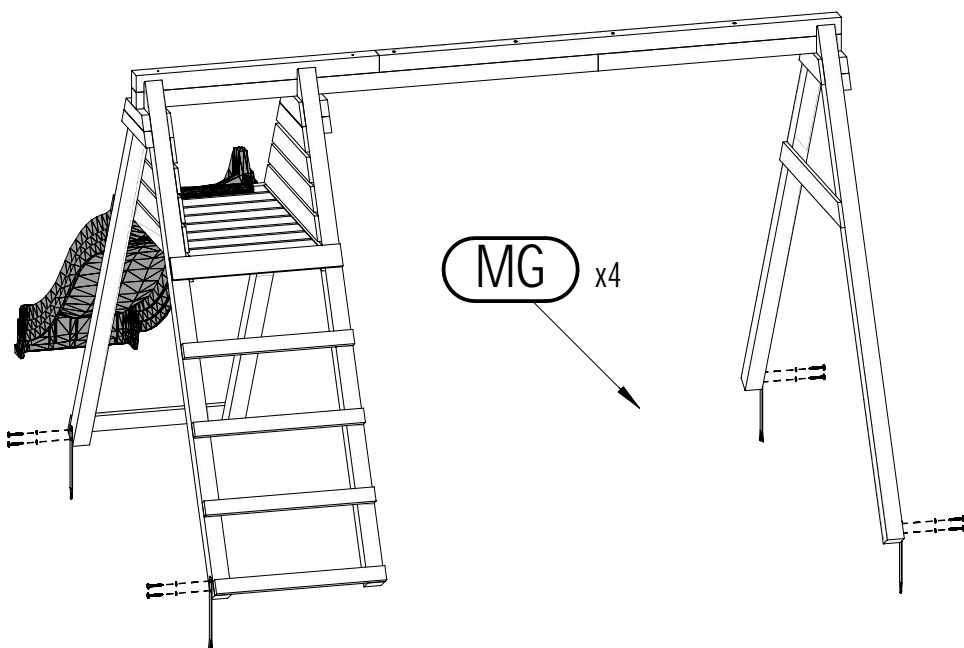
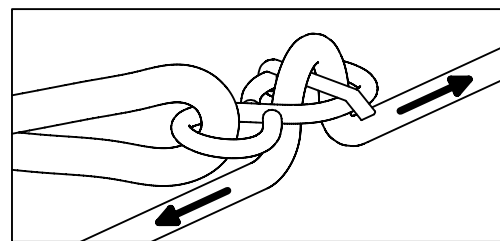

MG x4

P17 x8

T60 x8

17

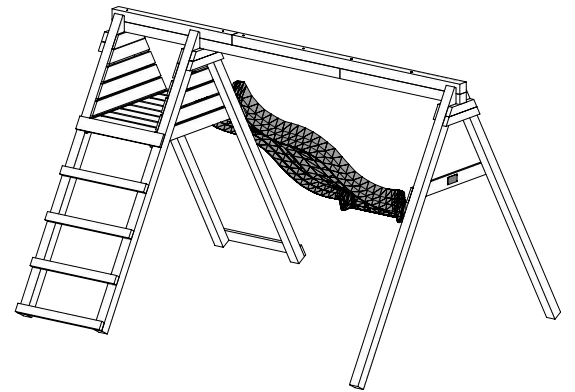
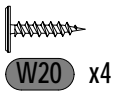
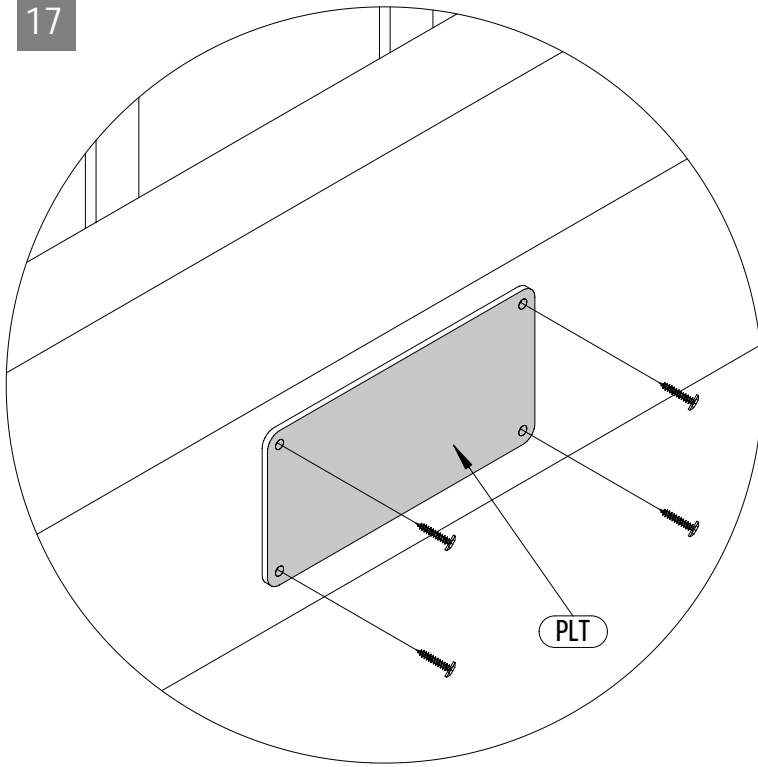

18

16

Zgodne z normą PN-EN 71 stosuj zalecenia producenta odnośnie odległości oraz metody mocowania poszczególnych elementów
In compliance with the standard PN-EN 71, apply guidelines of the producer in relation to distances and methods of fastening individual elements

BAXY