

KIPOR[®]

KIPOR POWER OPERATION MANUAL

PLEASE READ THIS MANUAL CAREFULLY.
IT CONTAINS IMPORTANT SAFETY INFORMATION.

WWW.KIPOR.COM

KIPOR[®]

WUXI KIPOR POWER CO., LTD.

Address: Beside Jingyi Rd, Third-stage Development Section
of Wangzhuang Industry Area, Wuxi High &
New Technology Industry Development Zone.

TEL: 0086-510-85205041
FAX: 0086-510-85203795
E-MAIL: kipor@kipor.com

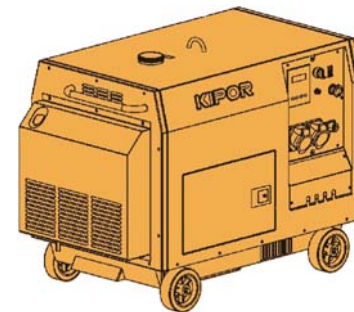

DIESEL GENERATOR

OPEN FRAME:

SINGLEPHASE: KDE8000E/EA

KDE12000E/EA

THREE PHASES: KDE8000E3/EA3

KDE12000E3/EA3

SILENT:

SINGLEPHASE: KDE8000T/TA

KDE12000T/TA

THREE PHASES: KDE8000T3/TA3

KDE12000T3/TA3

Three phases
 KDE8000EA3/TA3
 KDE12000EA3/TA3

ON/OFF Table for electric starting key

	①	②	③	④	⑤
OFF				○	○
ON	○	○			
START	○	○	○		

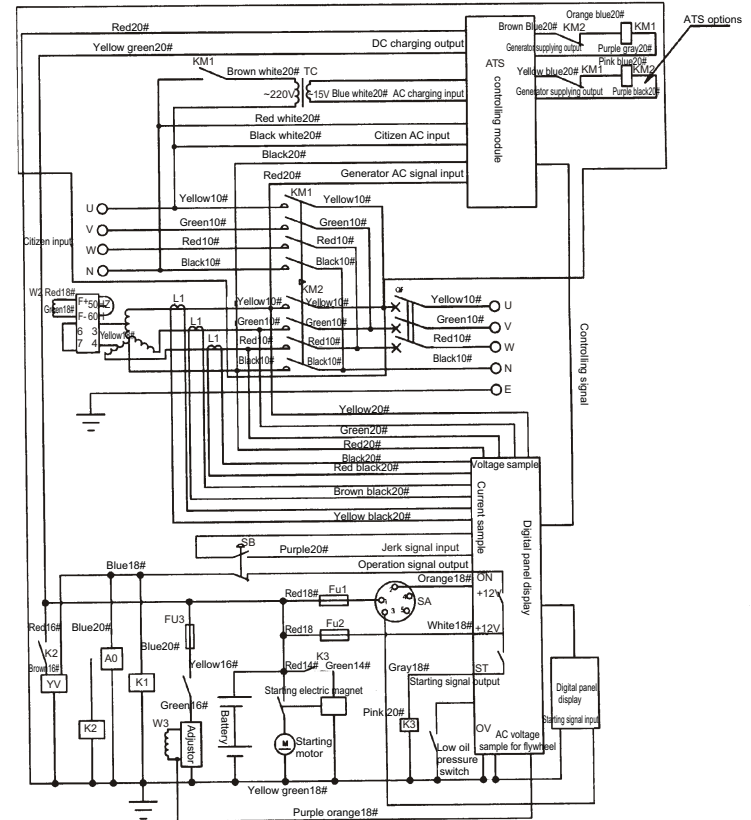

⚠ CAUTION

- Most appliance motors require more than their rated wattage for start-up.
- Do not exceed the specified current limit of any socket.
- Do not connect the generator set to a household circuit. This could cause damage to the generator set and to electrical appliances in the house.

5. WHEN CHARGING THE BATTERY

Battery electrolyte contains sulfuric acid. Protect your eyes, skin and clothing. In case of contact, flush thoroughly with water and get prompt medical attention, especially if your eyes are affected. Batteries generate hydrogen gas, which can be highly explosive. Do not smoke or allow flames or sparks near a battery, especially during charging. Charge the battery in a fully ventilated place.

KDE12000E/EA Double voltage output

ON/OFF Table for electric starting key

	①	②	③	④	⑤
OFF				○—○	
ON	○—○				
START	○—○	○—○			

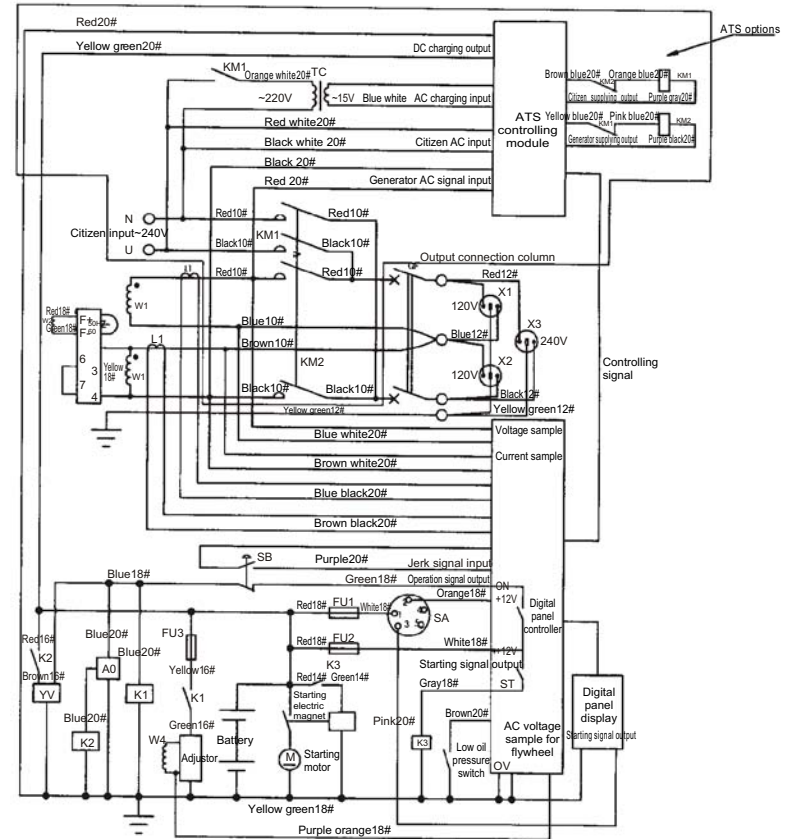

KDE12000E/EA single phase

ON/OFF Table for electric starting key

	①	②	③	④	⑤
OFF				○	○
ON	○	○			
START	○	○	○		

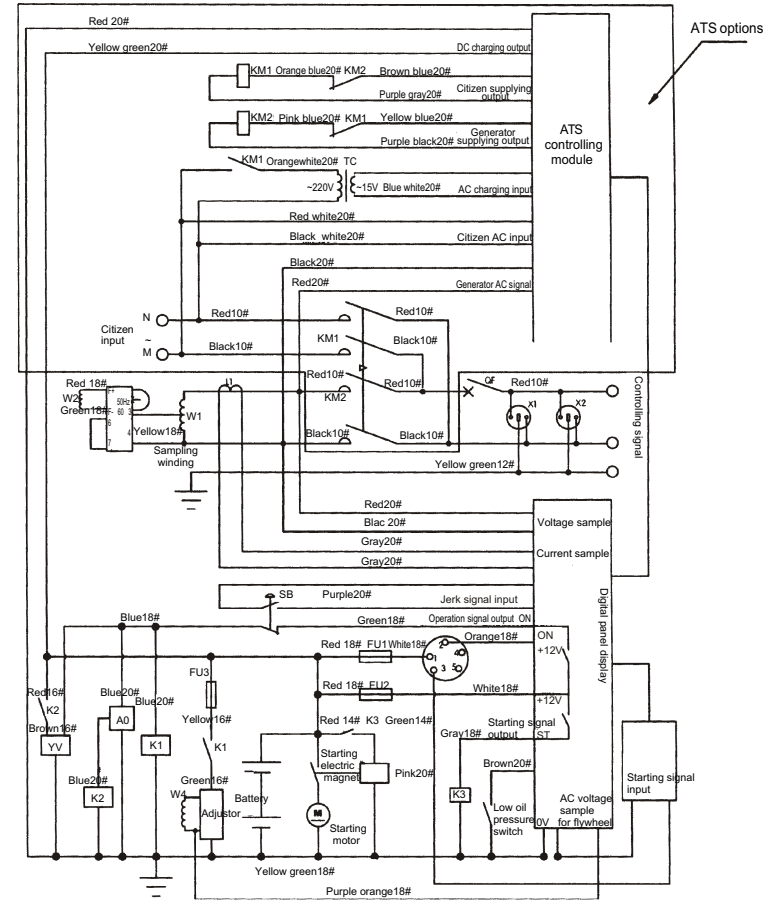

24	X3	DC receptacle	1	DC12V 8.3A	
23	X1 X2 X3	Receptacle	3	Honda or European style	
22	SA	Ignition switch	1	JK427	
21	TC	Transformer	1	220V/15V 40A	
20		Charging adjuster	1	35Ah	
19	GB	Battery	1	6-QW-36 12V 36Ah 310A	
18	AVR (Digital)	Automatic voltage adjuster	1		
17	L1	Current transformer	1	50/5mA	
16	W5	User charging winding			
15	W4	Flywheel generator winding			
14	W3	Secondary winding			
13	W2	Exciting winding			
12	W1	Generating/Sampling winding			
11	BX2011C	Fuse link		10A	
10	BX2011C	Fuse link		20A	
9	FU2、FU3	Four line fuse box	1	BX2041C	
8	FU1、FU4	Fuse (extend 6X30) 10A	2	BX201C	
7	YV	Throttle electric magnet	1		
6	KM1、KM2	AC contactor	2	A26-40-00	
5	K1,K2,K3	Relay	3	HFV4 12V 20A	
4				PLY-MB-ATS-S1	
3		Digital display	1	PLY-MB-D	
2		Digital module	1	PLY-50MB-2C	
1	QF	Breaker	1	D50/1620 25A	BeiYu electric appliance
	Code name	Name	Quantity	Material	Remark

1.MAIN TECHNICAL SPECIFICATINS AND DATA

Single-phase diesel generator

Model	KDE8000E/EA	KDE8000T/TA	KDE12000E/EA	KDE12000T/TA
Rated frequency	50	60	50	60
Rated output	5.5	6.5	8.5	9.5
Max. output	6	7.1	9.5	10.5
Rated voltage	115/230	120/240	115/230	120/240
Rated current	47.8/23.9	54/27	73.9/36.9	79.2/39.6
Rated rotation speed	3000	3600	3000	3600
Phase NO./Excitation mode	Single phase, three loops / Self-excitation and constant voltage(AVR)			
Power factor (cos φ)	1.0			
Insulation Grade	F			
Pole number	2			
DC output	12V/8.3A Without			
Working type	12 hours continuous running			
Engine Model	KD2V78F KD2V86F			
Engine Type	Two cylinder, V style, air cooled, four stroke, direct injection Two cylinder, V style, air cooled, four stroke, direct injection			
Cylinder NO.-bore × stroke mm	78 × 64 86 × 72			
Displacement L	0.610 0.836			
Compression ratio	20 : 1 12			
Rated power [kW/(r/min)]	7.2/3000 8/3600 11/3000 112/3600			
Fuel type	Diesel(Off(summer)-10#(winter)-35#(cold)			
Lube oil brand	L-ECD grade 15W30 or 15W40			
Fuel consumption g/KWh	≒ 340 ≒ 340			
Fuel tank capacity L	25 25			
Continuous running time h	11 9.5 7 6.5			
Overall dimension: L × W × H(mm)	T/TA: 1042 × 590 × 800 E/EA: 920 × 560 × 645 T/TA: 1136 × 650 × 860 E/EA: 930 × 620 × 690			
Dry weight(kg)	E/EA:155 T/TA:220 E/EA:185 T/TA:265			
Starting system	12 V Electric starter 12 V Electric starter			
Structure type	E/EA:Open frame T/TA:Silent			

NOTE: A is a digital panel

Three-Phase diesel generator

Model	KDE8000E3/EA3		KDE8000T3/TA3		KDE12000E3/EA3		KDE12000T3/TA3	
	50	60	60	7.5	50	60	60	
Rated frequency	6.5	7.5	60	7.5	50	60	60	
Rated output	5.2	6	60	6	10	11.5	11.5	
Max. output	7.1	8.2	60	8.2	8	9.2	9.2	
Rated voltage	400/230	416/240	400/230	416/240	400/230	416/240	416/240	
Rated current	9.4	10.4	3000	10.4	14.5	16	16	
Rated rotation speed	3000	3600	3000	3600	3000	3600	3600	
Phase NO./Excitation mode	Three phase four line."Y" connection							
Power factor (cosφ)	0.8(lag)							
Insulation Grade	F							
Pole number	2							
DC output	12V/8.3A							
Working type	12 hours continuous running							
Engine Model	KD2V78F							KD2V86F
Engine Type	Two cylinder, V style, air cooled, four stroke, direct injection							Two cylinder, V style, air cooled, four stroke, direct injection
Cylinder NO.-bore × stroke mm	78 × 64							86 × 72
Displacement L	0.610							0.836
Compression ratio	20 : 1							19 : 1
Rated power [kW]/(r/min)]	7.2/3000							10.3/3000
Fuel type	Diesel/0#(summer);-10#(winter);-35#(cold)							
Lube oil brand	L-ECD 级 15W30 or 15W40							
Fuel tank capacity g/KW.h	≅ 340							≅ 340
Fuel tank capacity L	25							25
Continuous running time h	11							7
Overall dimension: L × W × H (mm)	T/TA: 1042 × 590 × 800 E/EA: 920 × 560 × 645							T/TA: 1122 × 620 × 830 E/EA: 930 × 620 × 690
Dry weight (kg)	E3/EA3:155 T3/TA3:220							E3/EA3:185 T3/TA3:265
Starting system	12 V Electric starter							12 V Electric starter
Structure type	E3/EA3:Open frame T3/TA3:Silent							

NOTE: A is digital panel

KDE8000E/EA double-voltage optional output

ON/OFF Table for electric starting key

	①	②	③	④	⑤
OFF					
ON	○	○		○	○
START	○	○	○		

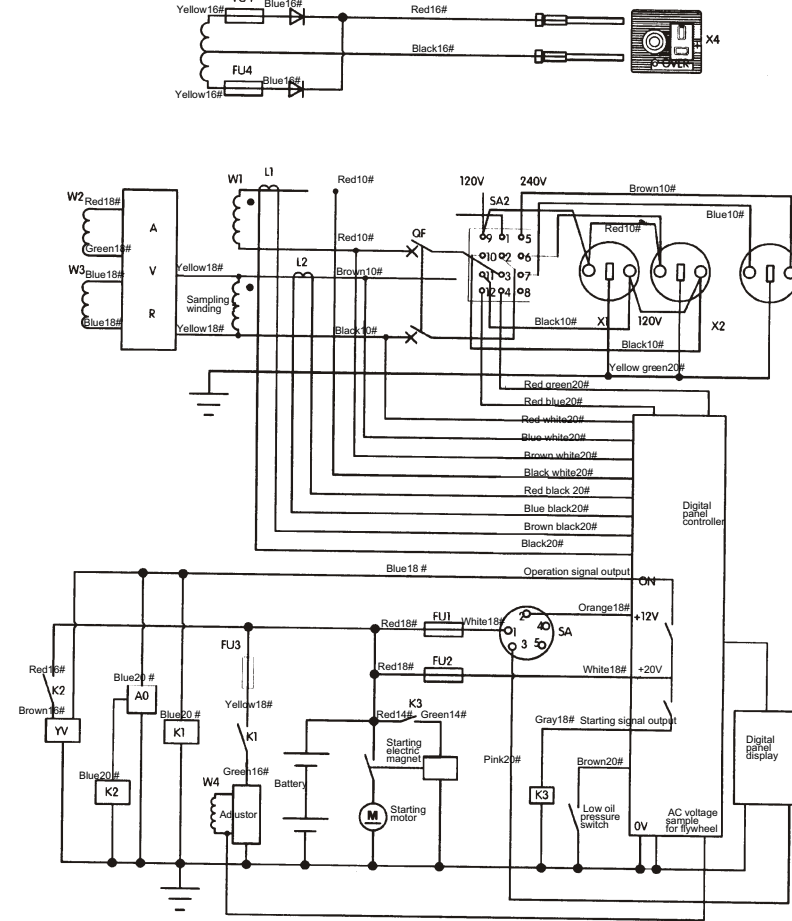

24	X3	DC receptacle	1	DC12V 8.3A	
23	X1 X2	Receptacle	2	Honda or European style	
22	SA	Ignition switch	1	JK427	
21	TC	Transformer	1	220V/15V 40A	
20		Charging adjuster	1	35Ah	
19	GB	Battery	1	6-QW-36 12V 36Ah 310A	
18	AVR (Digital)	Automatic voltage adjuster	1		
17	L1	Current transformer	1	50/5mA	
16	W5	User charging winding			
15	W4	Flywheel generator winding			
14	W3	Secondary winding			
13	W2	Exciting winding			
12	W1	Generating/Sampling winding			
11	BX2011C	Fuse link		10A	
10	BX2011C	Fuse link		20A	
9	FU2, FU3	Four line fuse box	1	BX2041C	
8	FU1, FU4	Fuse (extend 6X30) 10A	2	BX201C	
7	YV	Throttle electric magnet	1		
6	KM1, KM2	AC contactor	2	A26-40-00	
5	K1,K2,K3	Relay	3	HFV4 12V 20A	
4		ATS module	1	PLY-MB-ATS-S1	
3		Digital display	1	PLY-MB-D	
2		Digital module	1	PLY-MB-ATS-C	
1	QF	Breaker	1	D50/1620 25A	BeYu electric appliance
	Code name	Name	Quantity	Material	Remark

2. PARTS NAME

2.1 Parts name (E/EA, E3/A3 Type)

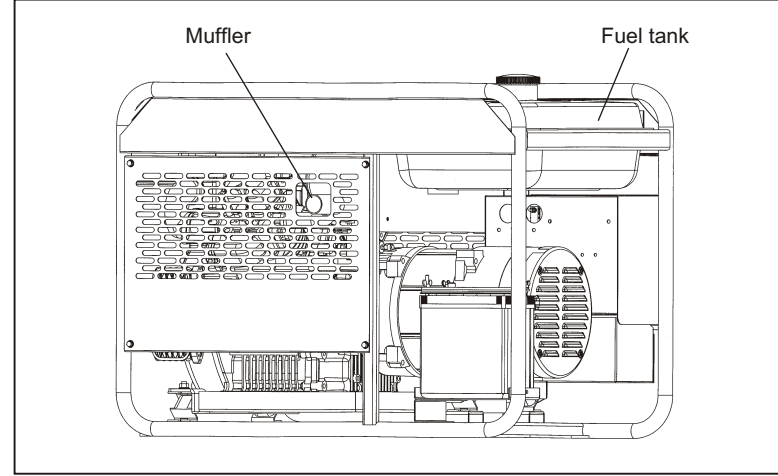
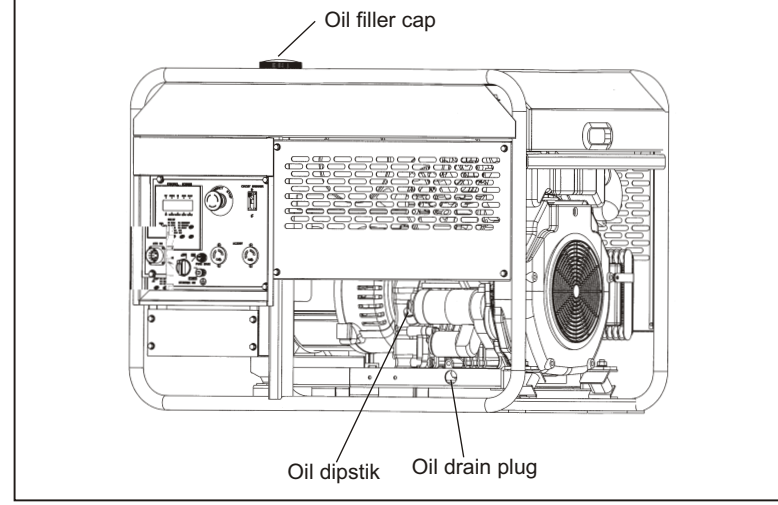

2.1 Parts name (T/TA, T3/TA3 type)

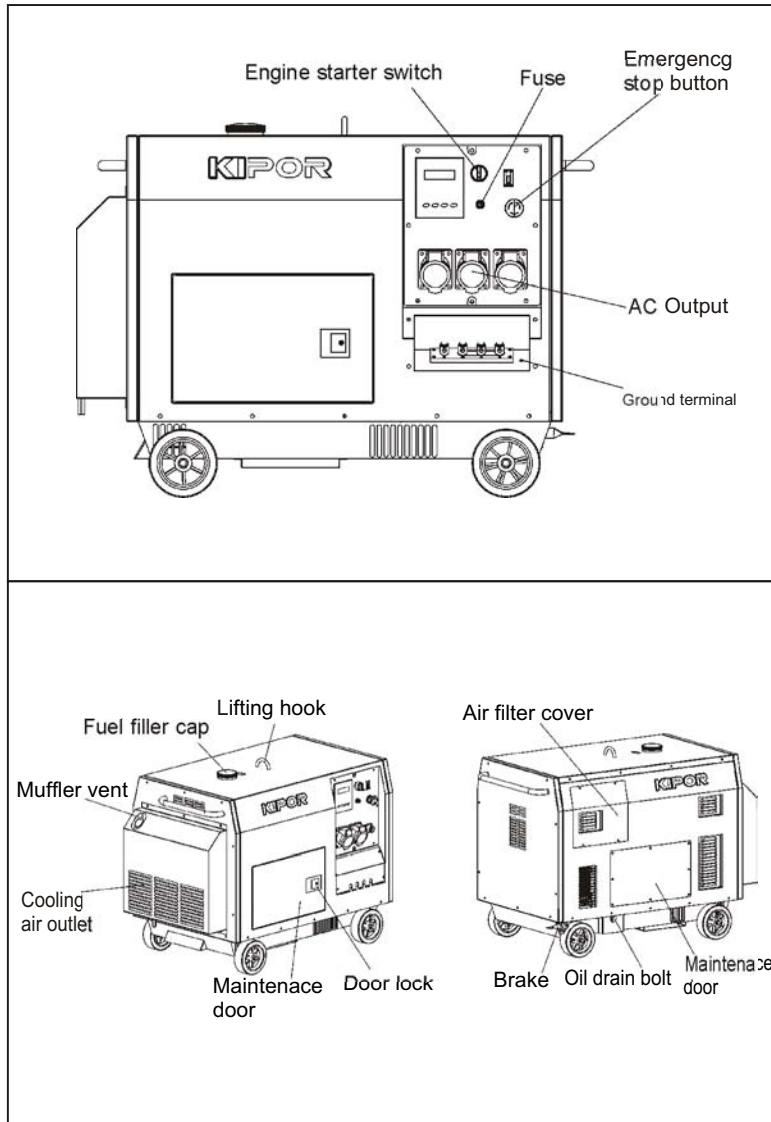

11. ELECTRIC SCHEMATIC DIAGRAM AND ELECTRIC WIRING DIAGRAM

KDE8000E/EA single phase

OFF and ON table for electric starting key:

	①	②	③	④	⑤
OFF					
ON					
START					

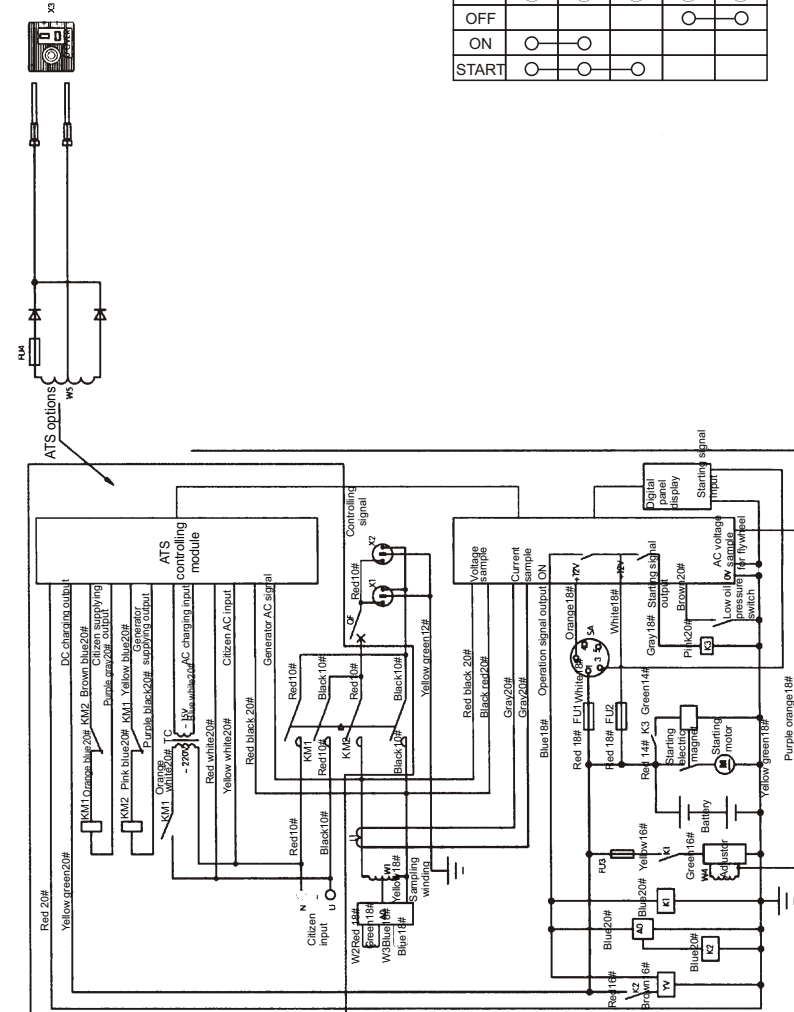

10. TROUBLESHOOTING

Fault	Troubleshooting
Engine can't start or fuel is not sufficient	Refill
The switch is not at START position	Turn it to START position
The fuel injection pump and nozzle don't deliver the fuel or deliver insufficient fuel	Remove the nozzle and repair it at test table
Check the engine oil level	The specified oil level should be between the upper level and lower level
The nozzle is dirty	Clean the nozzle
The battery has no electricity	Charge or replace it
Insufficient oil and low rotation speed	Adjust the throttle bolt and fill in oil
Generator sets can't work and the main switch is off	Turn on the main switch
The carton brush already worn	Replace the carton brush
Bad receptacle contact	Adjust the receptacle

2.2 Control panel

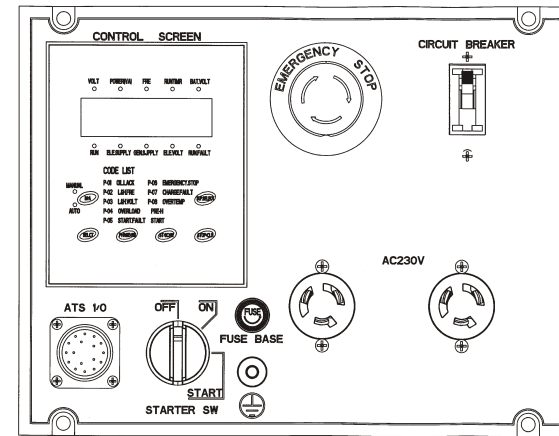

EA type panel

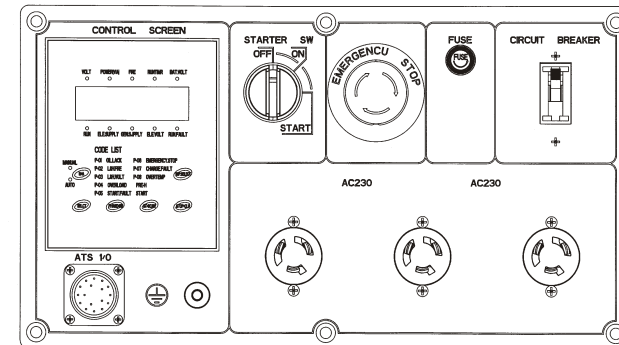

TA type panel

3. PREPARATION FOR STARTING

3.1 Selection and using of the fuel

■ Selection of fuel

Only use the light diesel, which is most suitable for the engine.

■ Keep dust and water out of the fuel

When filling the fuel tank from drums, make sure that no dust or water is mixed in the fuel. Otherwise the serious fuel injection pump and nozzle problems will result.

■ Do not overfill

Overfilling is very dangerous. Do not fill the tank beyond the top of the red plug inside the fuel filter.

WARNING

- Refuel in a well-ventilated area with the engine stopped.
- Do not smoke or allow flames or sparks in the area where the engine is refueled or where the fuel stored.
- Do not overfill the tank, make sure the filler cap is securely closed after refueling.
- Be careful not to spill fuel when refueling. If any fuel is spilled, make sure the area is dry before starting the engine

3.2 Check and refill the oil

WARNING

- Always check the oil level with the generator set on a level surface before starting and refill if necessary.
- The engine may be damaged if operated with insufficient oil, it is also dangerous to refill too engine oil as sudden increase in engine speed may be caused by its combustion.

CAUTION:

KIPOR KDE series generator set are equipped with low oil alarm system. This system will stop the engine automatically when the oil level falls below the lower level. This prevents accidents such as bearing seizures, etc.

9. LONG-TERM STORAGE

Do the following preparations for long-term storage:

- 1.Run the generator for 3 minutes and then stop.
- 2.If the generator is still hot after stop running, please drain out the original oil and fill in fresh oil.
- 3.Screw off the bolt of cylinder cover, fill in 2CC oil and tighten the bolt.
- 4.Clean the generator and store it in dry area.

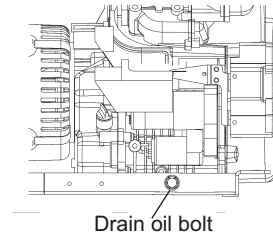

1. Drain out the fuel from the fuel tank.
2. Drain out the fuel from the fuel tank.
Screw off the small screw of the fuel cock and pull out the filter from the filler port.
3. Wash the filter thoroughly with diesel fuel.
Loosen the fastening nut, bottom cover and delivery discs for cleaning the deposit carbon.
- 8.5 Tighten cylinder head bolt
Tightening the cylinder head bolt requires a special tool. Do not try yourself. Contact with KIPOR agent.
- 8.6 Check the injection nozzle and fuel injection pump
 1. Adjust the clearance of the intake/exhaust valves.
 2. Grind the intake/exhaust valves.
 3. Replace the piston ring

⚠ WARNING

■ Do not perform the injection nozzle test near an open fire or any other kind of fire. The fuel spray may ignite. Do not expose bare skin to the fuel spray. The fuel may penetrate the skin and cause injury to the body. Always keep your body away from the nozzle.

- 8.7 Check and refill the battery electrolyte and charge the battery
The diesel uses a 12V battery. Battery electrolyte will be lost through continuous charging and discharging.
Before starting, check for physical damage to the battery and also the electrolyte levels, and refill the distilled water till to the upper lever if necessary. When actual damage is discovered, replace the battery.
Check the battery electrolyte monthly.

⚠ WARNING

■ The battery electrolyte contains sulfuric acid. Protect your eyes, skin and clothing. In case of contact, flush thoroughly with water and get prompt medical attention, especially if your eyes are affected.
■ The battery exhaust hydrogen gas, which can be highly explosive. Do not smoke or allow flames or sparks near the battery, especially during charging.

- Select the most applicable oil
It is very important to select the applicable oil in order to keep up the performance and life of the generator set. If inferior oil is used, or if your oil is not replaced periodically, the risk of piston seizure, piston ring sticking and accelerated wear of the cylinder liner, bearing and other moving components will increase significantly. So the generator set life will be shortened. KIPOR recommends CC/CD oil classified by API. Choose the applicable viscosity oil according to the local ambient temperature.

- 3.3 Check the air cleaner
1. Screw off the wing nut, remove the air cleaner cover and take out the element.

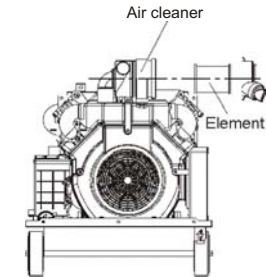

⚠ CAUTION:

- Do not wash the element with detergent.
- Replace the element when its output decrease or a bad exhaust color is noticed.
- Never run the generator set without the element, otherwise the rapid engine wear will result.



2. Reattach the air clearer cover and screw on the wing nut.

3.4 Check the generator set

1. Turn off the main switch and any other loads.

⚠ WARNING:

- Be sure to turn off the main switch before starting.
- The generator set should be earthed to prevent electric shocks.

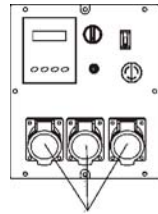

AC output receptacle

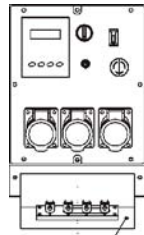

Ground terminal

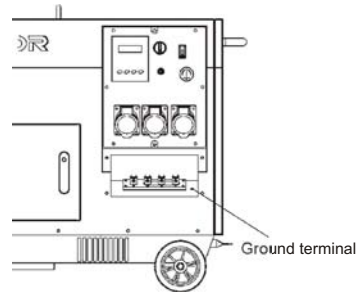

Ground terminal

2. Use dual voltage type generator sets

Be sure to place the changeover switch in the correct position for the rated voltage of the working instrument.

⚠ CAUTION:

■ Before starting the engine, be sure to turn the switches of the control panel (lighting apparatus, motor, etc.) to their "OFF" position. If the switches are not in the "OFF" position, the sudden application of load when the engine is started could be very dangerous.

8.1 Replace engine oil

Remove the oil filler cap. Remove the drain plug and drain the old oil while the engine is still warm. The plug is located on the bottom of the cylinder block. Tighten the drain plug and refill with the recommended oil.

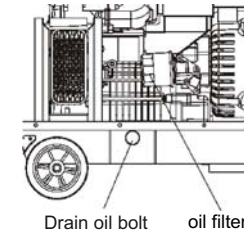

Drain oil bolt oil filter

8.2 Clean the engine oil filter

Cleaning time	Every 6 months or 500 hours
Replace if necessary	

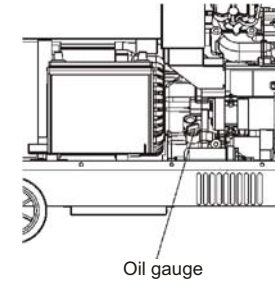

Oil gauge

Cleaning time	Every 6 months or 500 hours
---------------	-----------------------------

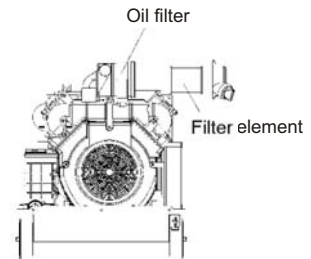

Oil filter

Filter element

⚠ CAUTION

■ Never run the engine without the element or with a defective element.

8.4 Clean and replace fuel oil filter

The fuel oil filter also has to be cleaned regularly to insure maximum engine output.

Clean time	Every 6 months or 500 hrs
Replace time	Every year or 1000 hrs

8. PERIODIC CHECK AND SERVICE

Periodic check and service are very important for keeping the engine in good condition and durable. The chart below indicates what checks to make and when to make them.

⚠ WARNING

- Shut off the engine before performing any service. If the engine must be run, make sure the area is well ventilated. The exhaust contains poisonous carbon monoxide gas.
- After the generating set has been used, clean it immediately with a cloth to prevent

8.1 Maintenance table:

Item	Intervals	Every month	First month or 20 Hrs	Third month or 100 Hrs	Sixth month or 500 Hrs	Every year or 1000 Hrs
Check and refill oil		○				
Drain out fuel oil			○			
Check and refill engine oil		○				
Check for oil leakage		○				
Check and tighten fastening parts	○				● Tighten the cylinder head bolts	
Replace engine oil			○ (First time)	○ (After second time)		
Clean engine oil filter					○ (Replace if necessary)	
Replace air cleaner element	shorter maintenance period for dusty area				○ (Replace)	
Clear fuse element					○	●
Check fuel injection pump					●	
Check nozzle					●	
Check fuel pipe					●	
Adjust clearance of intake/exhaust valves			●		●	
Grind intake/exhaust valves						●
Replace piston ring						●
Check battery electrolyte	Every month					
Check carbon brush and slip ring					●	
Check insulation resistance	The generating set has been stored more than 10 days ○					

Note: "●" indicates that special tools are required, please contact with KIPOR agent.

3.5 How to open the cabinet door and covers of the silent generator set.

1. Turn the lever clockwise and open the cabinet door for daily inspection.
2. Loosen the bolt of the air cleaner check port cover to check the air cleaner.
3. Screw off the wing nut to open the cover of nozzle, then check the nozzle.

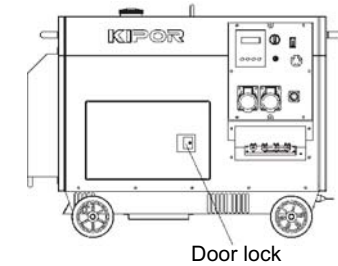

3.6 Break-in period operation

The first 20hrs are the break-in period of the engine, the operator must obey the following items:

- Warm up the engine 5 minutes after the initial starting. Run the engine at low speed and zero load before the engine becomes warm.
- Avoid applying any heavy loads during the break-in period. KIPOR recommends to run the engine at 3000r/min with 50% load in break-in period.
- Replace the oil on time.

Replace the oil while the engine is warm after 20-hours-running, the old oil will be drained out completely.

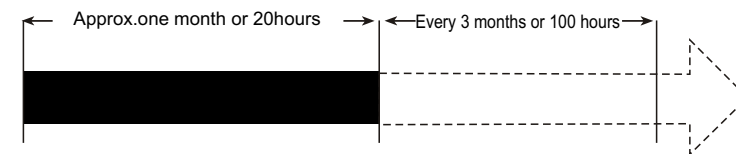

4. START THE GENERATOR SET

⚠ WARNING

- DO not hook up tools or other apparatus to the generator set before starting.

⚠ WARNING

- Please tighten the screw on the cylinder to prevent any rainwater&dust,which may cause wearing of inner parts as well as break-downs

4-1 Recoil starting

1.Start the engine according to the following procedures:

- Open the fuel cock.
- Set the engine speed lever at the RUN position.
- Remove hands from the startor switch after the engine started , and the switch will return to the RUN position automatically.
- It will spend 10s to start, if the engine doesn't start after 10s, please wait 15s to restart it.

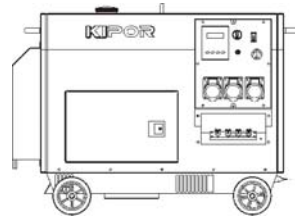

Start switch

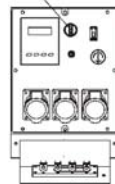

⚠ CAUTION

- Running the starter motor for long time, it may consume the power, even destroy the battery.
- Put the start switch at the "ON" position while the engine is running.

2. Battery

You must check the electrolyte each month, if the electrolyte level is below the lower limit line, please add the water to the upper limit line.

⚠ CAUTION

- If the electrolyte is too little, the engine will not start. While if the electrolyte is too much, the electrolyte will corrupt the parts. You should keep the electrolyte level between the lower limit and upper limit.

7. STOP THE GENERATOR SET

7.1 Stop the generator set normally

1. Cut off the load
2. Turn off the air switch of the generator set
3. Turn off the engine switch, and turn the engine switch to "OFF" position

⚠ CAUTION

- In the case that the speeds handle is on "Stop" position, while the engine is still running. You should turn the fuel switch to the "OFF" position, or loose the high pressure oil pipe bolt to stop the engine.
- Don't stop the engine with load; you should cut off the load first.







7.2 Emergency shut down

1. While the set is running, the operator should keep close watch on the running state of the set. If there is anything abnormal, you should stop the set following the right procedure.
2. If there is any emergency, it will result in big destroy or personal accident, such as the set overspeed, short circuit, electric shock and so on. The operator should stop the generator decidedly. Press the "emergency stop button", and the generator will stop immediately.
3. Revolving the "emergency stop button" according to the arrow direction to replace it.

⚠ CAUTION

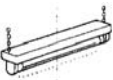
- Don't use the "emergency stop button" in usual cases, which will do certain harm to your generator.

6.3 Electrical appliance particularly motor-driven equipment will produce very high current while starting, the below table provides the reference for connecting these apparatus to the generator set.

TYPE	WATTAGE		TYPICAL APPLIANCE	EXAMPLE		
	STARTIN	GRATED		APPLIANCE	STARTIN	GRATED
<ul style="list-style-type: none"> Incandescent lamp Heating appliance 	X1	X1	 Incandescent lamp  TV	 Incandescent lamp 100W	100VA (W)	100VA (W)
<ul style="list-style-type: none"> Fluorescent lamp 	X2	X1.5	 Fluorescent lamp	 40W Fluorescent lamp	80VA (W)	60VA (W)
<ul style="list-style-type: none"> Motor driven equipment 	X3~5	X2	 Refrigerator  Electric fan	 Refrigerator 150W	450-750VA (W)	300VA
<ul style="list-style-type: none"> switch power Rectify power 	X2	X2	Motor 、 Electric drill 、 Computer UPS power	Computer UPS power 200W	400VA	400VA

5. OPERATE THE GENERATOR SET

5.1 Operate the generator set

- Warm up the engine without load three minutes.
- Concerning the generator set with Low Oil Alarm System, check that the Low oil alarm Lamp is not lit.

⚠ CAUTION

- For the generator set with Low Oil Alarm System, the Oil Alarm Lamp will activated by low oil pressure or engine oil shortage, simultaneously, the engine will stop. The engine will stop immediately if restarted without refilling the engine oil. Check the oil level and refill.
- Do not loosen or readjust either the engine speed limiting bolt or fuel injection limiting bolt, the performance will be affected.

5.2 Checks during the running

- Whether there is abnormal sound or vibration;
- Whether the engine misfires or runs rough;
- Check the color of the exhaust. (Is it black or too white?)
 If you notice any of the above-mentioned phenomenon happened, stop the engine and find out the fault cause or contact with KIPOR agent.

⚠ CAUTION

- If the engine has been running, the muffler will be very hot. Be careful not to touch the muffler.
- Never refill the fuel tank while the engine is running.

6. LOAD

CAUTION

- Do not start 2 or more machines simultaneously. Start them one by one.
- Do not use floodlights together with other machines.
- First start the motor load, and then start resistance load.

6.1 AC application

1. Be sure to run the generator set at rated speed, otherwise AVR (Automatic Voltage Regulator) will produce the forced excitation. If the running is for a long time under such condition, AVR will be burned out.
2. After switching on the air switch, observe the voltmeter on the panel of the control cabinet, the voltmeter should point to $230V \pm 5\%$ (50Hz) for single-phase generator set; $400V \pm 5\%$ (50Hz) for three-phase generator set, then the loading can be carried out.
3. When the double voltage generator set changes over the voltage, the air switch should be set at "OFF" position. Otherwise the generator set and electric devices will be burned out and damaged.
4. Connect the equipment to the generator set in order. For the matter of the motor load, firstly the heavy-duty motor should be connected, then the light-duty motors. If the operation is false, the generator set will lag or stop suddenly. It is necessary to unload the generator set immediately and turn off the main switch and do checks.
5. Three-phase generator set
 - Balance three phases during the operation. Stop the engine for check if the tolerance exceed 20%. Be sure to keep the tolerance among three phases less than 20%
 - The load for each phase must below the rated load as well as the current must less than rated current.
A,B,C,D(or U,V,W,N) phase arrangement should be from left to right, or clockwise.
 - Concerning starting the three phase asynchronous motors, first start the heavy-duty motors, then start the light-duty motors.

NOTE

- If overloading of the circuit trips the AC circuit protector, reduce the electrical load on the circuit, and wait a few minutes before resuming operation.

6.2 DC application

1. DC terminals are only for charging 12V battery.
2. Set the air switch at "OFF" position while charging. On the 12V output terminals, a charge switch can be connected so the switch can be used for on-and-off purpose.
3. Concerning the automatic type battery with the leads, be sure to disconnect the negative leads of the battery while charging.

CAUTION

- Connect the positive and negative poles of the battery with the positive and negative poles of DC terminals separately. Do not confuse them, otherwise the battery and generator set will burn out.
- Do not connect the positive pole of the battery with its negative pole, otherwise the battery damage will result.
- Do not connect the positive pole of the DC terminal with its negative pole, otherwise the generator set damage will result.
- When a large capacity battery is charged, excessive current flows, the fuse for the direct current will burn out.
- Do not run the generator set while it is still connected with the battery.
- Do not use DC12V and AC at the same time.

CAUTION

- Battery exhausts explosive gas. Keep sparks, flames, and cigarettes away from the battery. To prevent from creating a spark near the battery, always connect the charging cables to the battery first and only then to the generator set. When disconnecting, you should disconnect the cables at the generator set first.
- Charge the battery at a well-ventilated place.
- Before charging, remove the cap from each cell of the battery.
- Stop charging if the electrolyte temperature exceed 45°C