

PLAYGROUND
SPIELPLATZ
LEIKKITELINE

PLAC ZABAW
AIRE DE JEUX
KLÄTTERSTÄLLNING

(313 x 83 x h252cm)

003_06450_02122020

MATTI

INSTALLATION INSTRUCTIONS
MONTAGEANLEITUNG
ASENNUSOHJEET

INSTRUKCJA MONTAŻU
GUIDE D'INSTALLATION
MONTERINGSANVISNINGAR

Warranty period - 2 years from purchase date
Garantiezeit - 2 Jahre ab Kaufdatum
Takuu aika - 2 vuotta ostopäivästä

Okres gwarancji - 2 lata od momentu zakupu towaru
Période de garantie - 2 ans à compter de l'achat
Garantiperiod - 2 år från inköpsdatum



CE
EN - 71

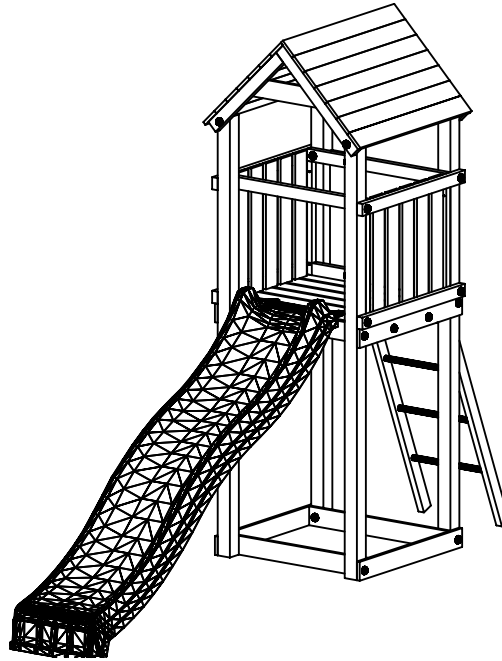
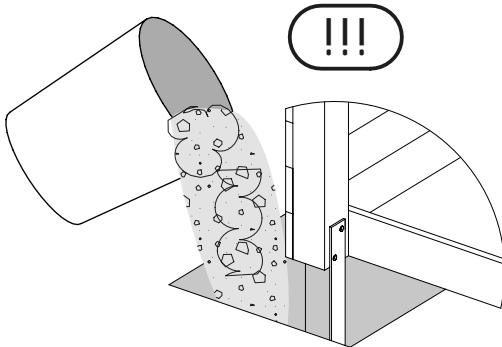

WARNINGS!

Only for home use.
Dedicated for external use only.
Not suitable for children under 3 years old.
Risk of falling down and/or hitting.
Maximum user weight is up to 50 kg.
Maximum number of users staying on the playground at the same time: 4.

OSTRZEŻENIA!

Tylko do użytku domowego.
Przeznaczony do użytku na zewnątrz.
Nie przeznaczony dla dzieci poniżej 3 roku życia.
Niebezpieczeństwo upadku i/lub uderzenia.
Maksymalna waga użytkownika to 50 kg.
Maksymalna liczba użytkowników przebywających na placu zabaw w tym samym czasie: 4.

VAROITUKSET

Vain kotitalouskäyttöön.
Tarkoitettu vain ulkokäyttöön.
Ei sovellu alle 3-vuotiaalle lapsille.
Putoamis- ja/tai loukkaantumiswaara.
Käyttäjän enimmäispaino on 50 kg.
Samanaikaisten leikkitelinien käyttäjien enimmäismäärä: 4.

ACHTUNG!

Nur für den privaten, häuslichen Bereich.
Ausschließlich für die Verwendung im Freien.
Nicht geeignet für Kinder unter 3 Jahren.
Stolper- und / oder Sturzgefahr
Höchstgewicht pro Einzelkind beträgt 50 kg
Der Aufenthalt auf diesem Spielturm ist max. : 4. Kindern gleichzeitig erlaubt.

AVERTISSEMENT!

Aire exclusivement destinée à un usage privé.
Aire exclusivement destinée à un usage en extérieur.
Prévue pour les enfants de plus de 3 ans.
Danger de chute ou de choc.
Poids maximal d'un utilisateur : 50 kg.
Nombre maximal d'utilisateurs présents en même temps sur la même aire de jeux: 4.

VARNINGAR

Endast för hemmabruk.
Endast avsedd för användning ute.
Ej lämplig för barn under 3 år.
Risk för att falla ner och/eller slå sig.
Max användarvikt är 50 kg.
Maximalt antal samtidiga användare på klätterställningen: 4.

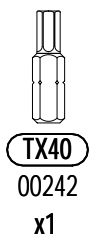
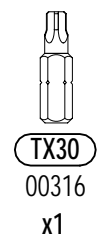
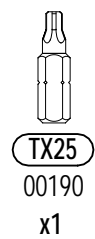
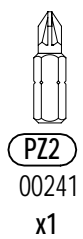
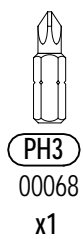
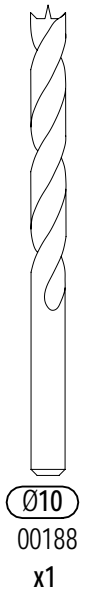
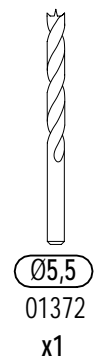
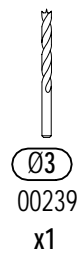
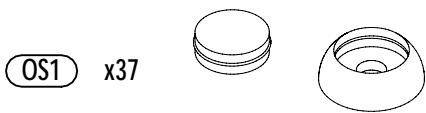
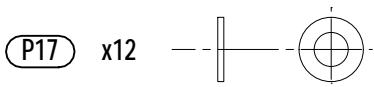
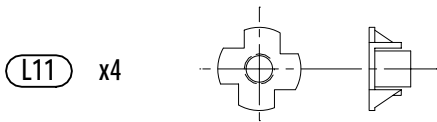
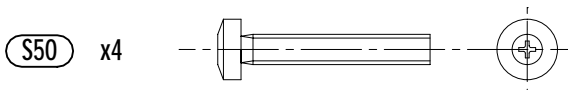
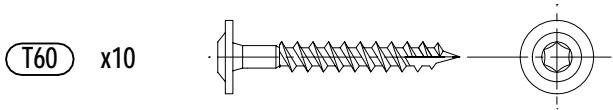
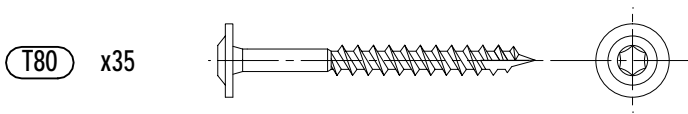
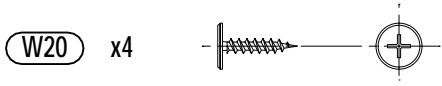
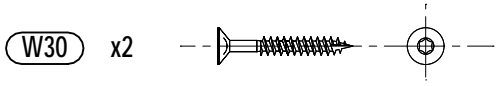
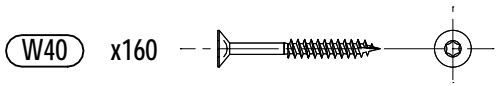
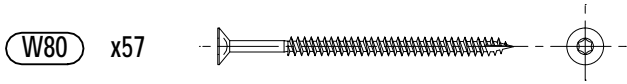

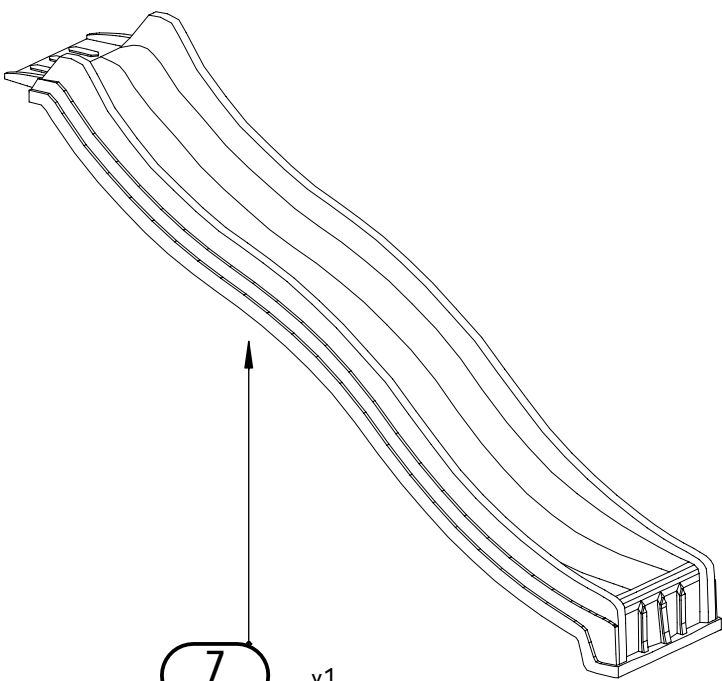
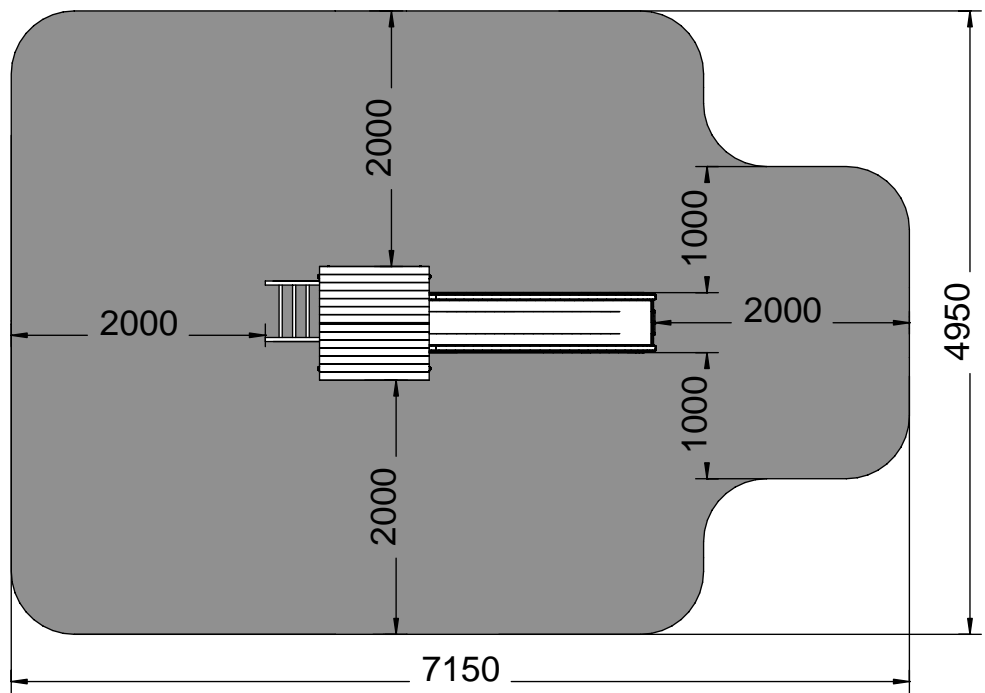

Z
00137 x1

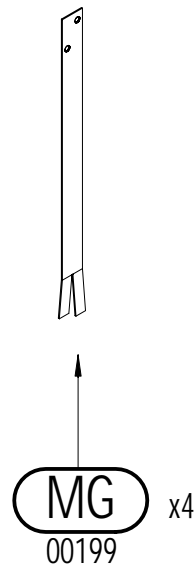

MG
00199 x4

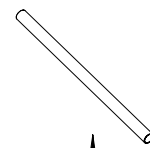

SD
00135 x4



PLT
00197 x1

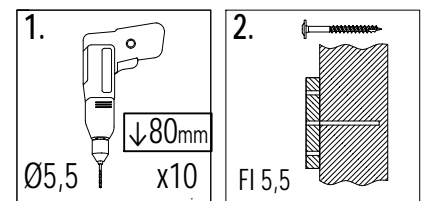
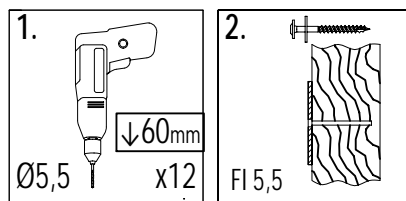
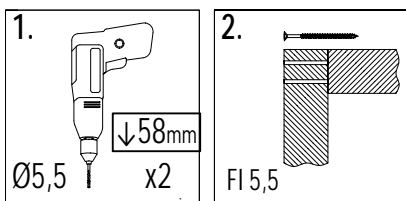
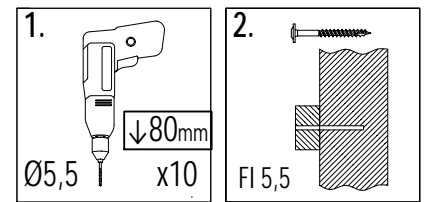
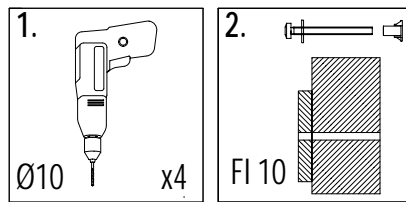
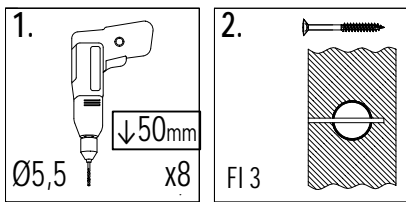
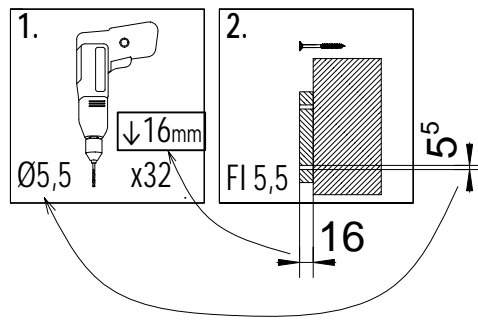
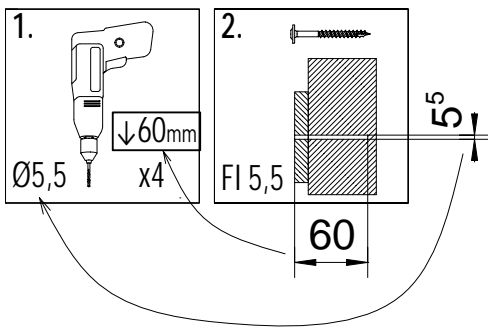
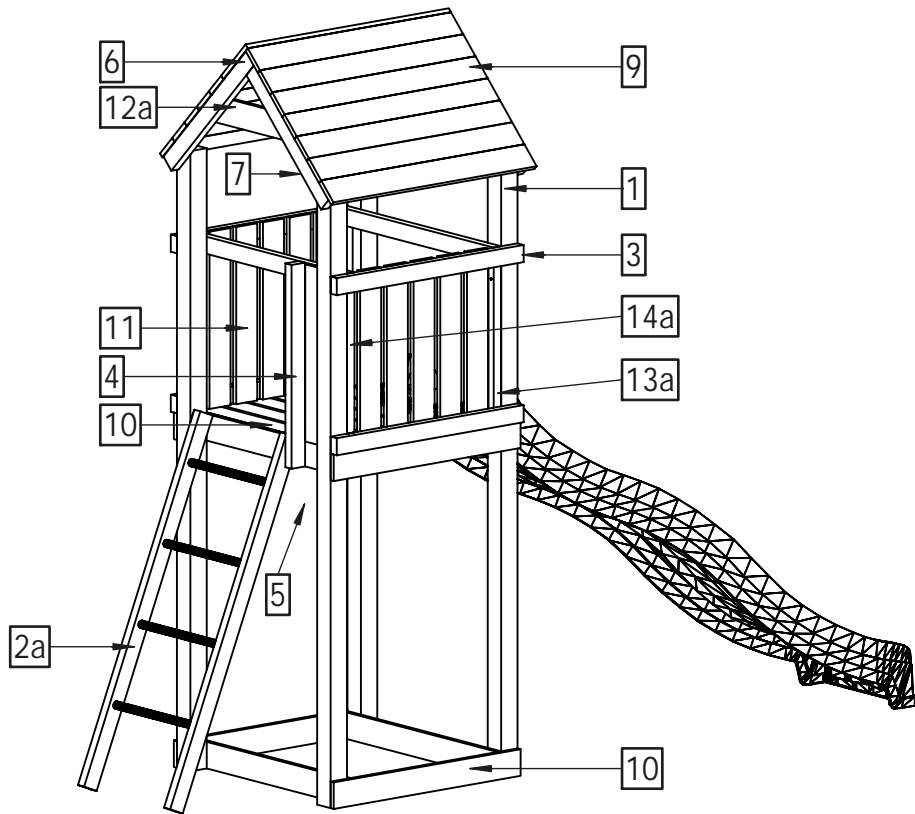

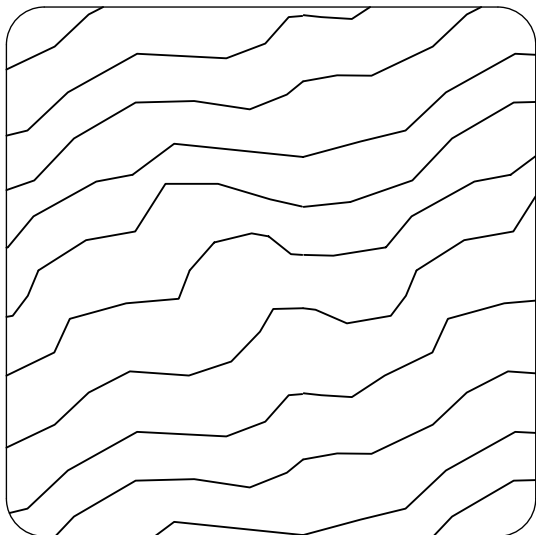

7,0 x 7,0 cm

Lp.	Wymiary [mm]	szt.
1	70x70x2100mm	4

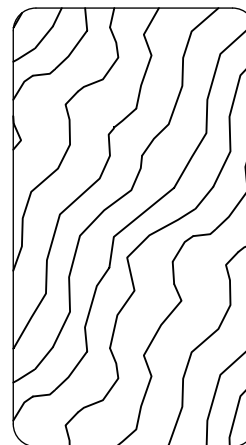

3,2 x 5,8 cm

Lp.	Wymiary [mm]	szt.
2a	32x58x1300mm	2
3	32x58x800mm	6
4	32x58x690mm	1
5	32x58x628mm	3
6	32x58x610mm	2
7	32x58x550mm	2
8	32x58x250mm	1

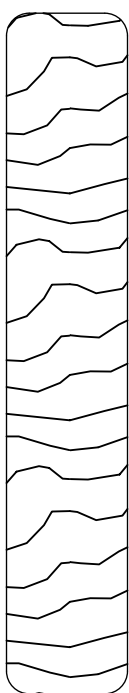

1,6 x 9,0 cm

Lp.	Wymiary [mm]	szt.
9	16x90x870mm	14
10	16x90x800mm	14
11	16x90x600mm	11
12a	16x90x560mm	2

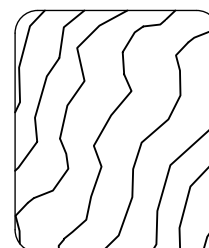

2,7 x 3,2 cm

Lp.	Wymiary [mm]	szt.
13a	27x32x542mm	3
14a	27x32x484mm	1

01

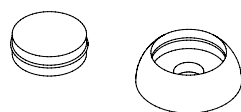
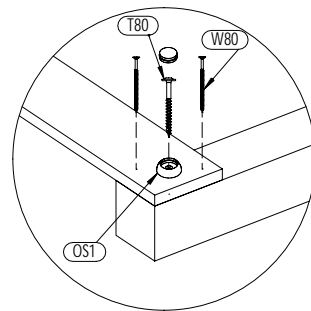
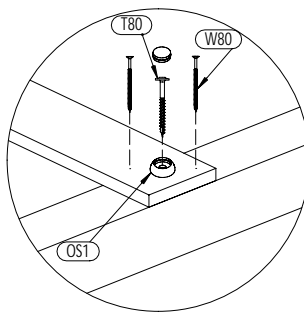
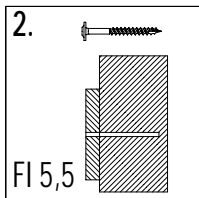
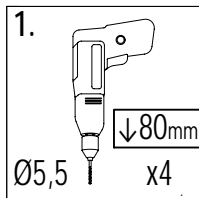

OS1 x4



W80 x8



T80 x4

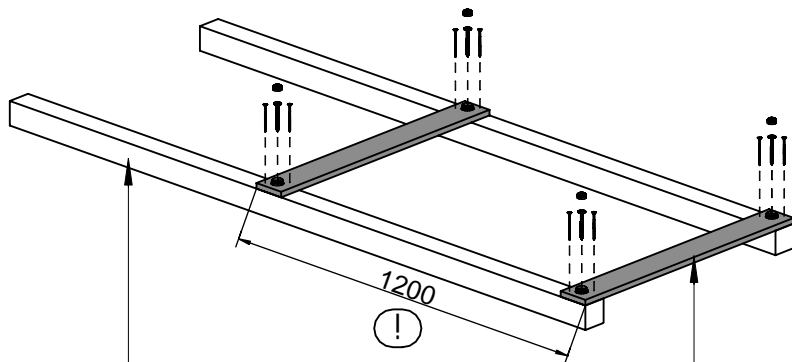

1 $7,0 \times 7,0 \times 210\text{cm}$
x2

10 $1,6 \times 9,0 \times 80\text{cm}$
x2

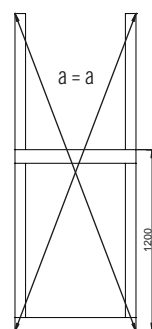
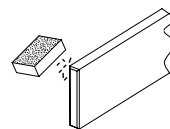

02

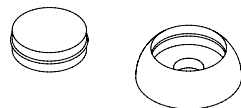
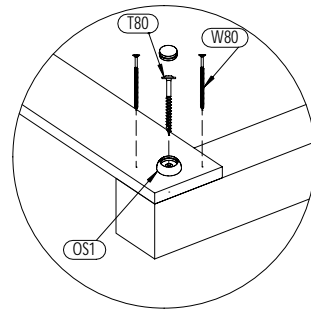
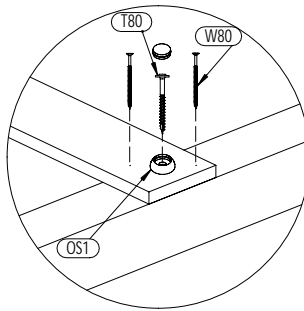
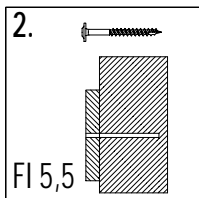
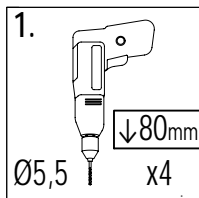

OS1 x4

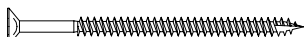

W80 x8

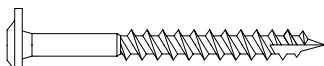

T80 x4

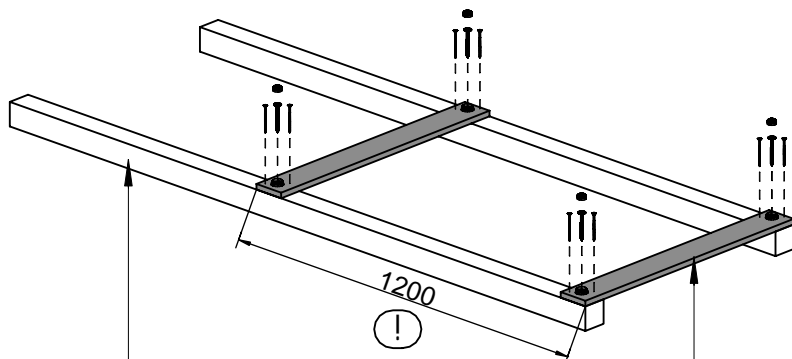

1 $7,0 \times 7,0 \times 210\text{cm}$
x2

10 $1,6 \times 9,0 \times 80\text{cm}$
x2

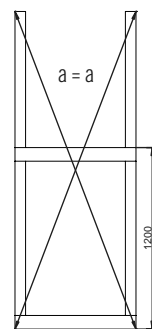
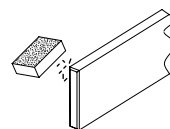

1. $\downarrow 80\text{mm}$
Ø5,5 x4

2. FI 5,5

10 1,6x9,0x80cm x4

OS1 x2

W80 x8

T80 x4

1. $\downarrow 80\text{mm}$
Ø5,5 x4

2. FI 5,5

OS1 x2

W80 x8

T80 x4

90° 90°

05

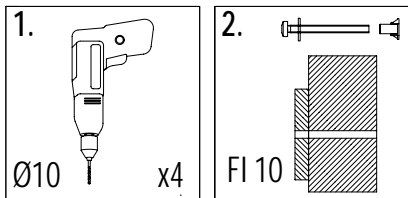

5 3,2x5,8x62,8cm x2

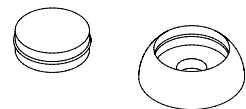

OS1 x4

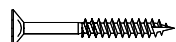

W40 x4

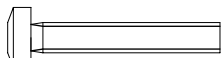

S50 x4



P17 x4



L11 x4

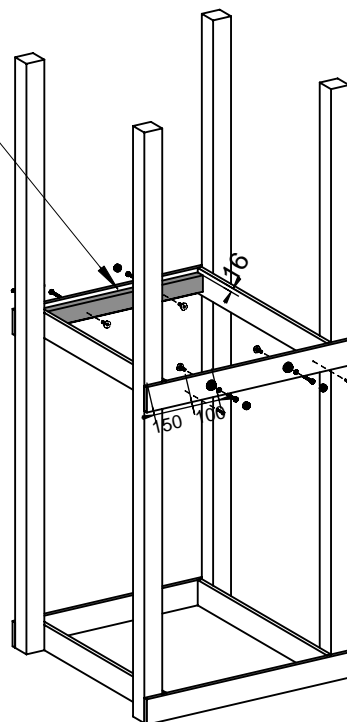
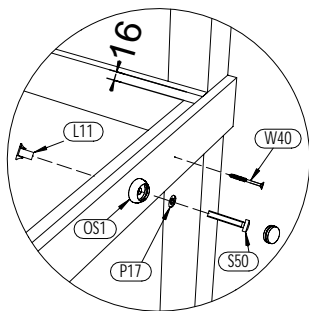

06

5 3,2x5,8x62,8cm x1

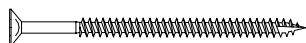
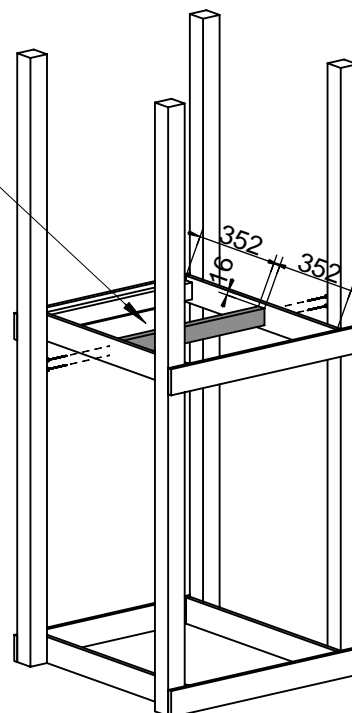
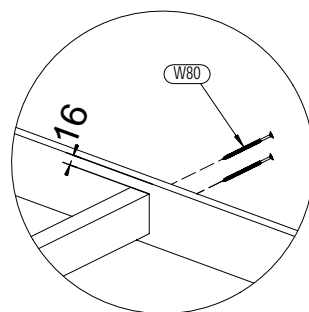

W80 x4

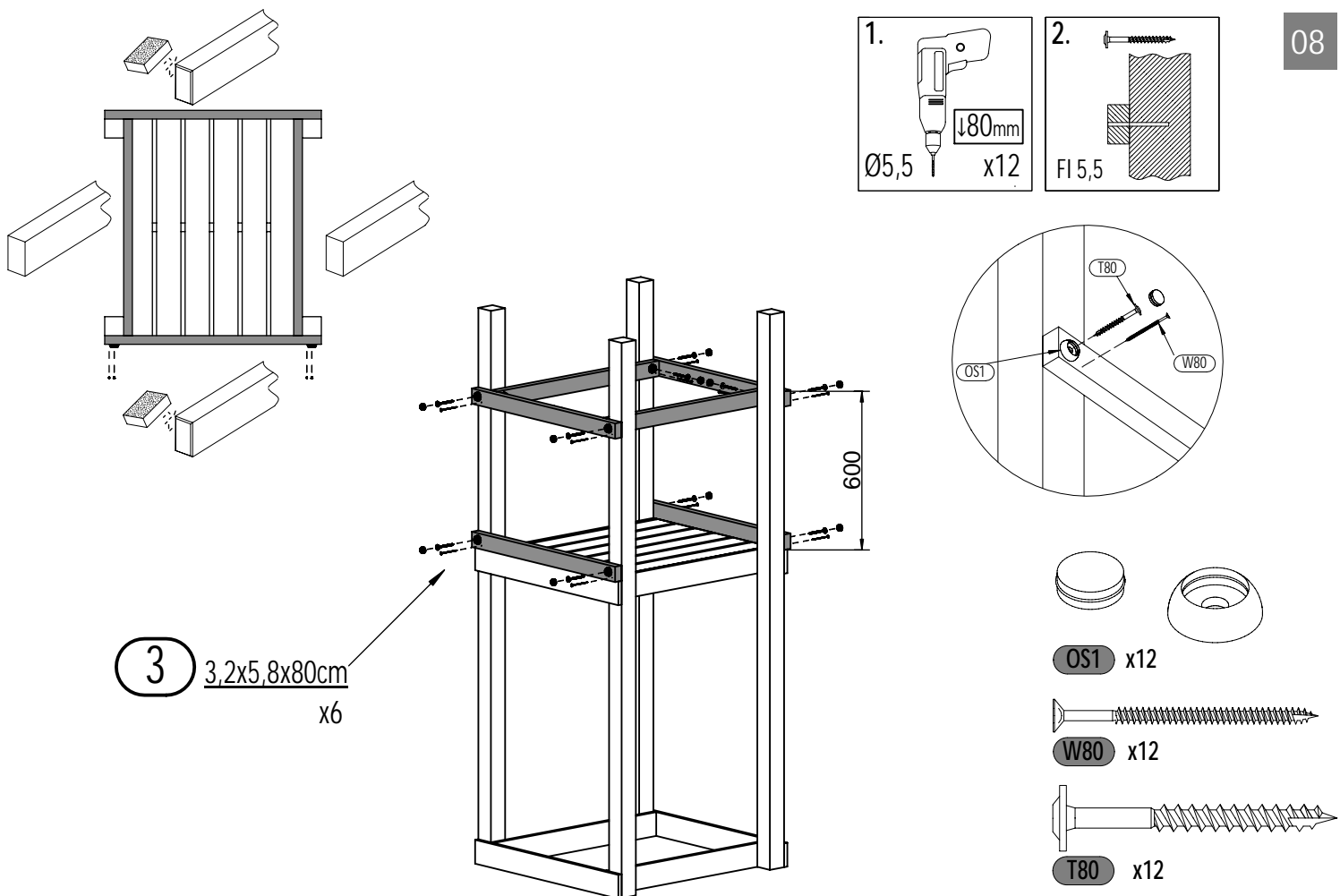
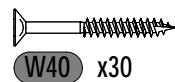
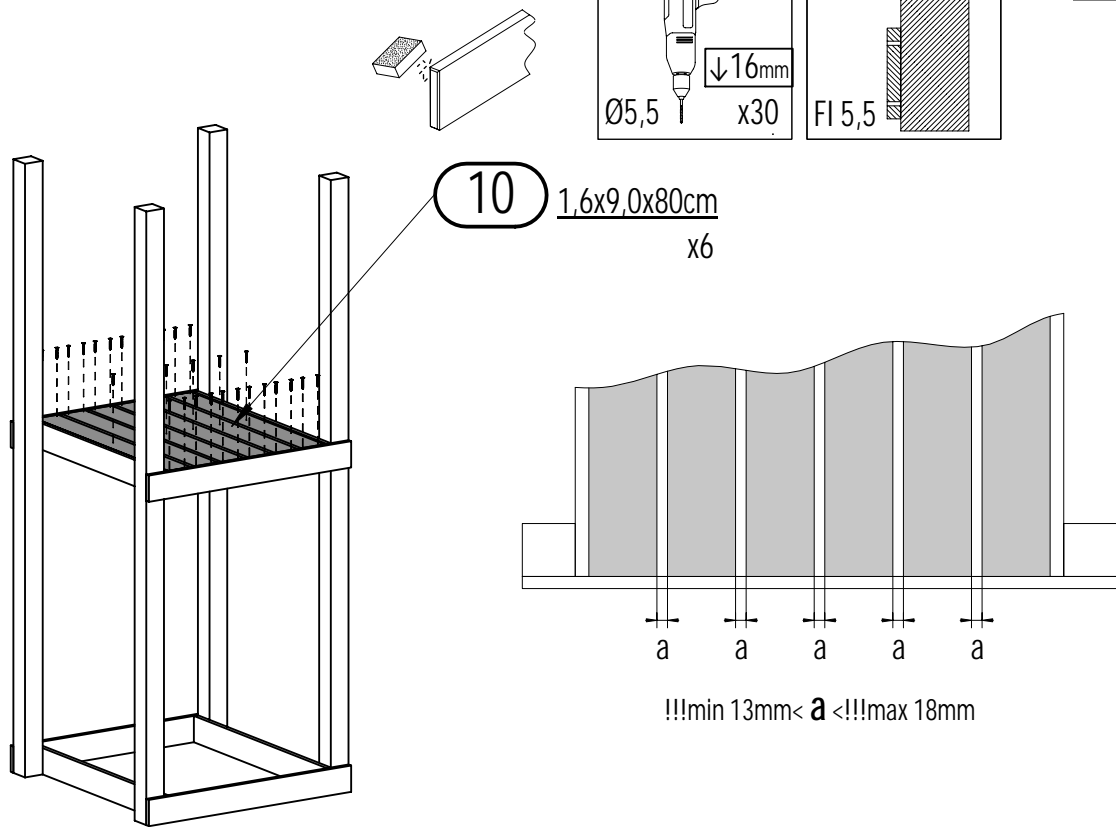

Zgodne z normą PN-EN 71 stosuj zalecenia producenta odnośnie odległości oraz metody mocowania poszczególnych elementów
In compliance with the standard PN-EN 71, apply guidelines of the producer in relation to distances and methods of fastening individual elements

09

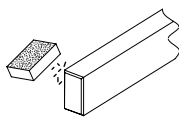
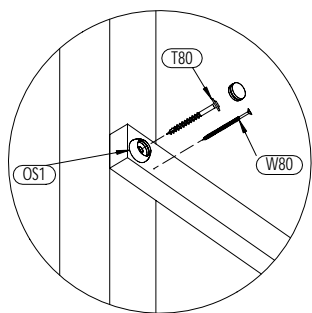
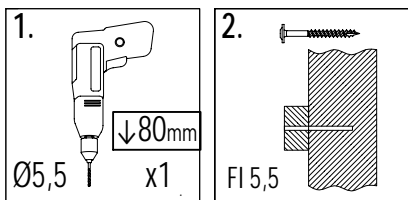

8 3,2x5,8x25cm
x1



OS1 x1

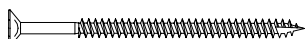

W80 x1

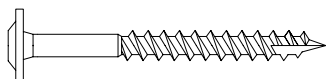

T80 x1

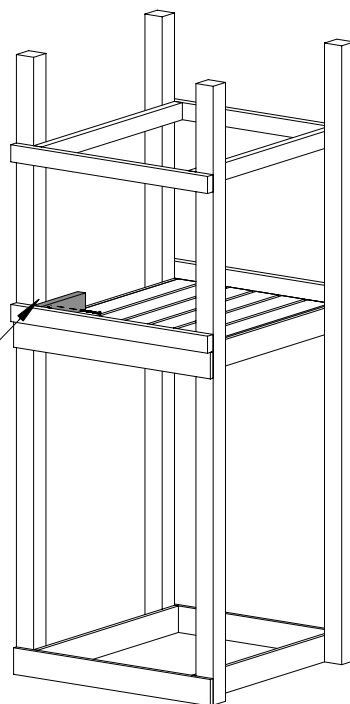

10

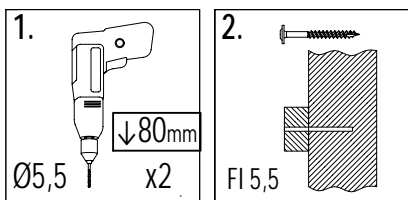

4 3,2x5,8x69cm
x1

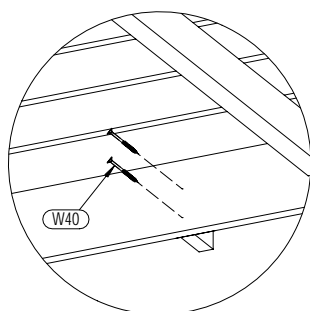
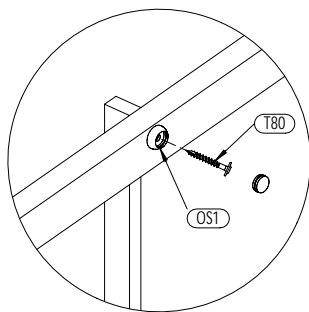

OS1 x2

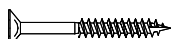

W40 x2

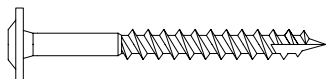

T80 x2

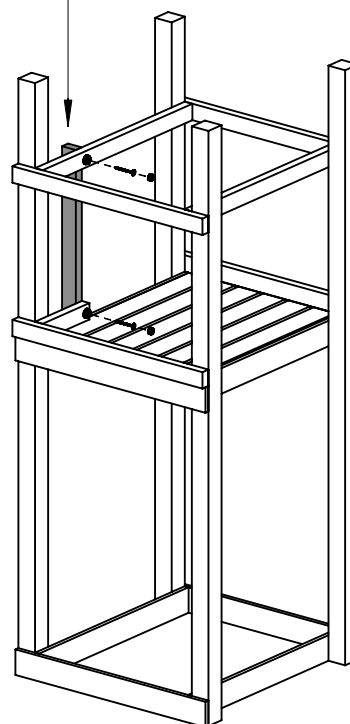

10 MATTI

Zgodnie z normą PN-EN 71 stosuj zalecenia producenta odnośnie odległości oraz metody mocowania poszczególnych elementów
In compliance with the standard PN-EN 71, apply guidelines of the producer in relation to distances and methods of fastening individual elements

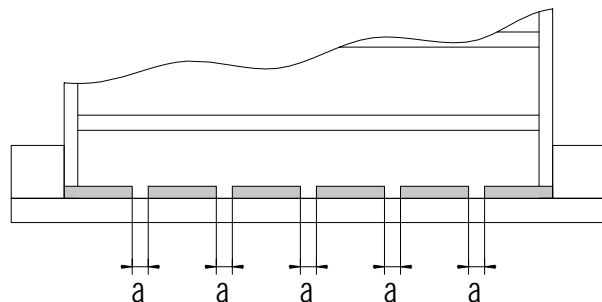
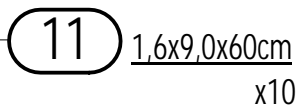
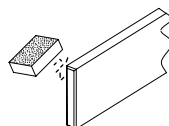
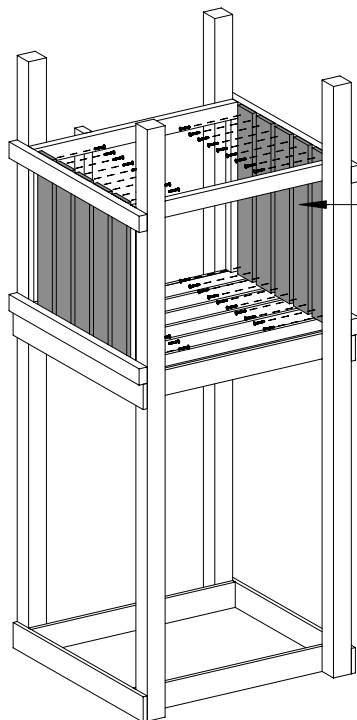
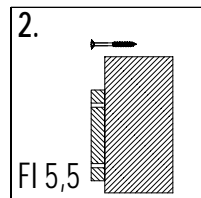
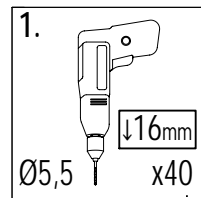
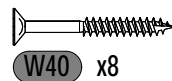
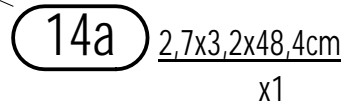
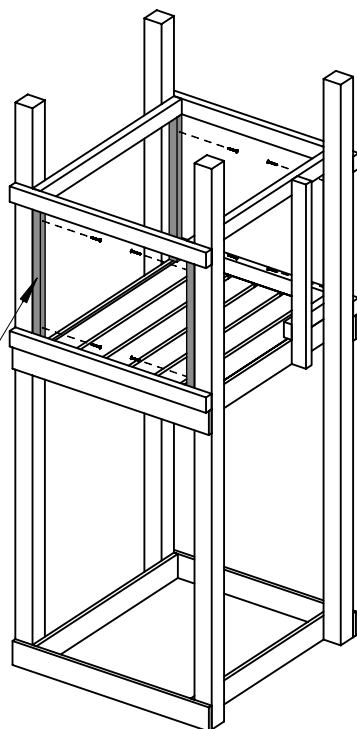
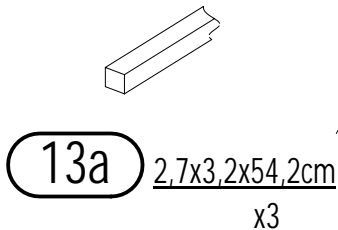
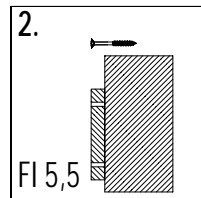
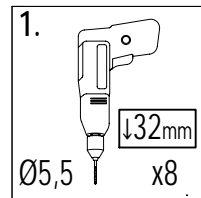

!!!min 13mm < a < !!!max 23mm

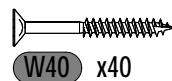

13

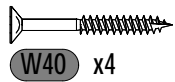
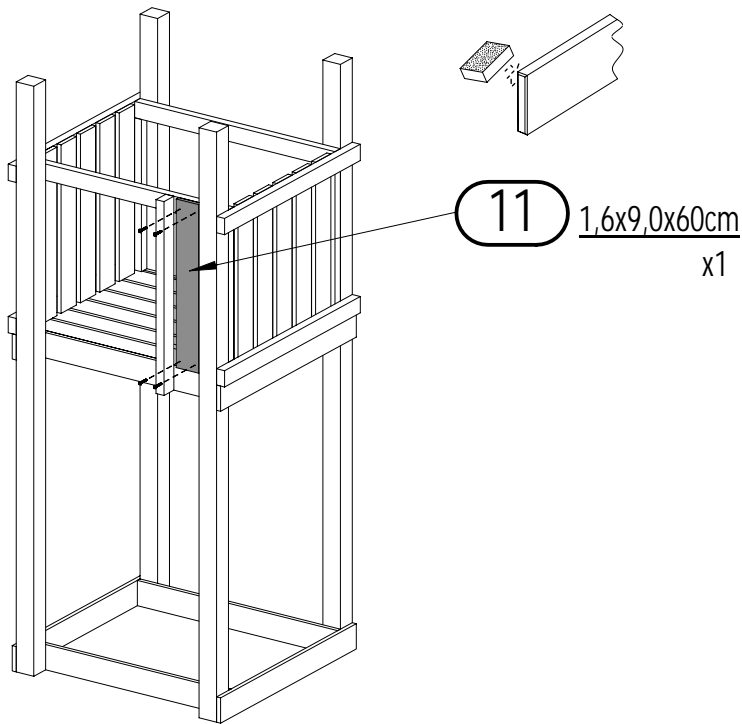
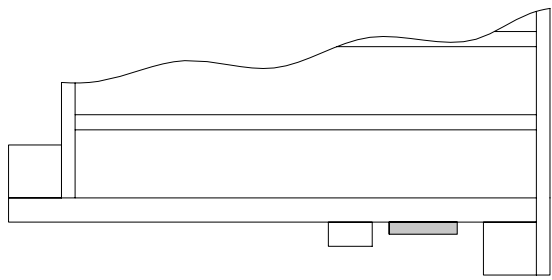
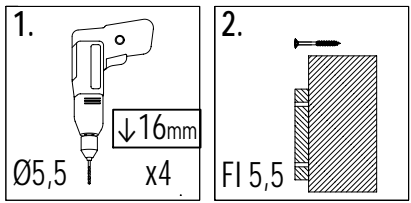

14

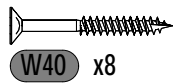
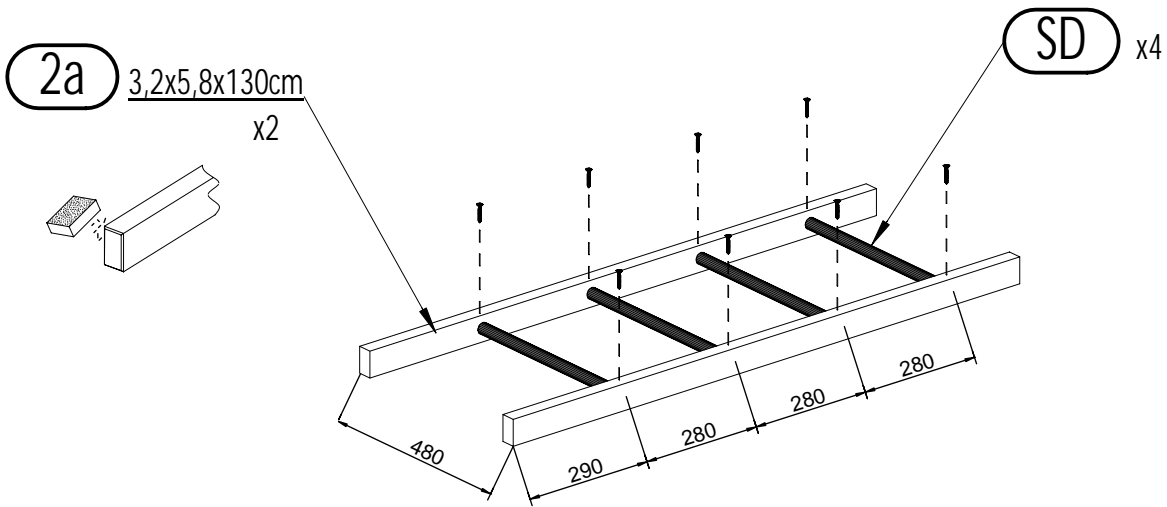
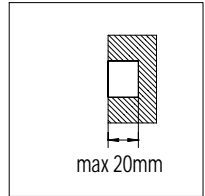
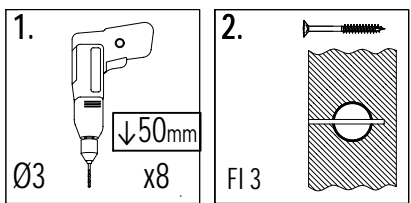

12 MATTI

Zgodnie z normą PN-EN 71 stosuj zalecenia producenta odnośnie odległości oraz metody mocowania poszczególnych elementów
 In compliance with the standard PN-EN 71, apply guidelines of the producer in relation to distances and methods of fastening individual elements

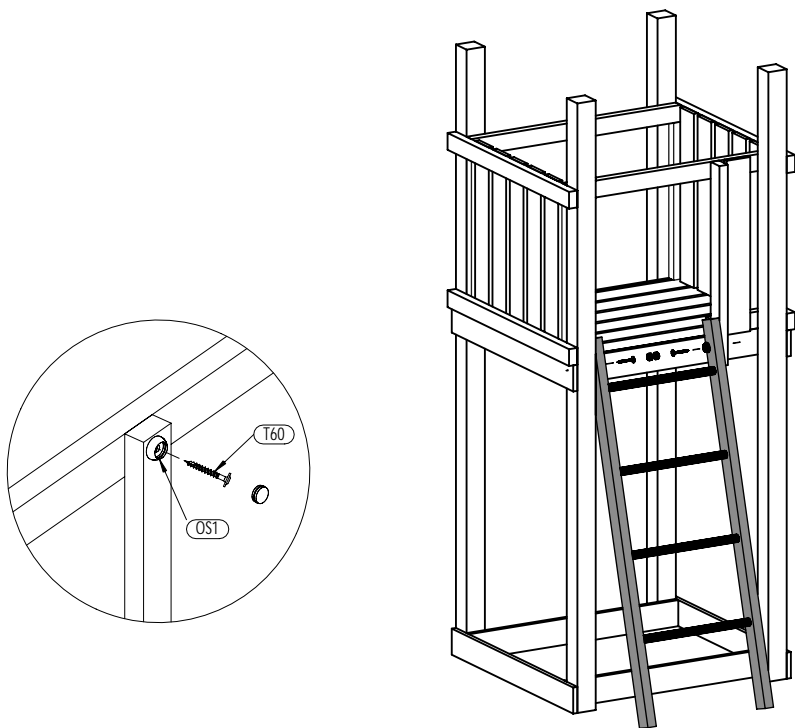

OST x2



T60 x2

x2

12a 1,6x9,0x56cm x1

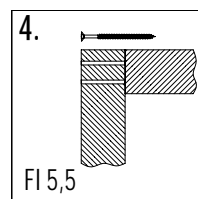
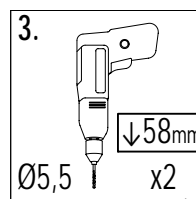
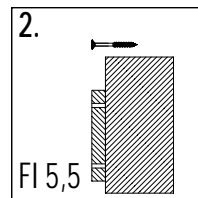
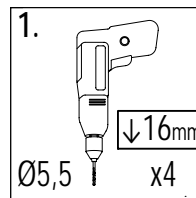
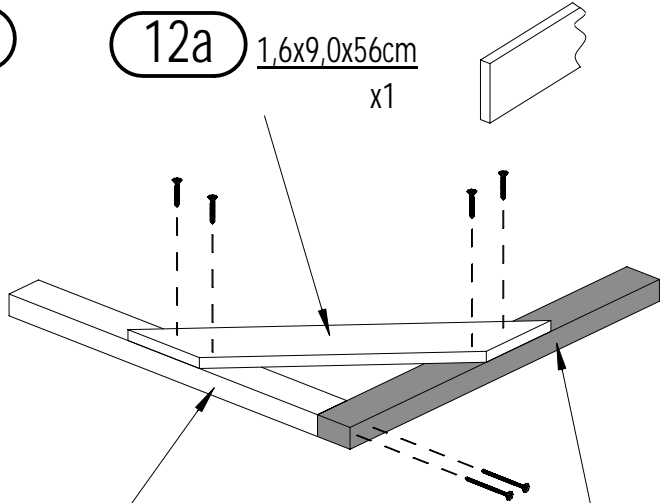

7 3,2x5,8x55cm x1

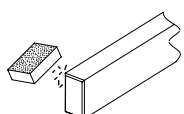

6 3,2x5,8x61cm x1

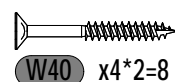
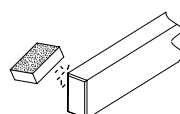

W40 x4*2=8

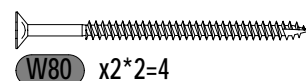

W80 x2*2=4

17

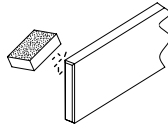
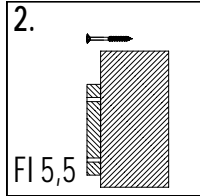
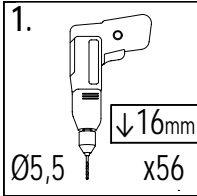

9 1,6x9,0x87cm
 x14

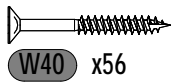
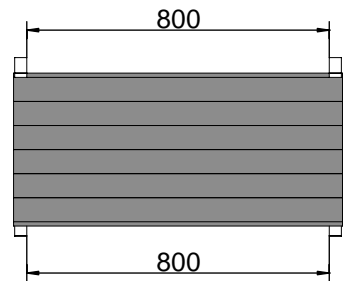
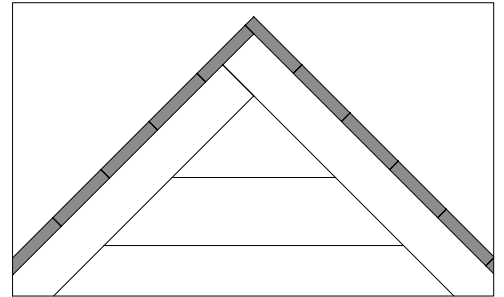
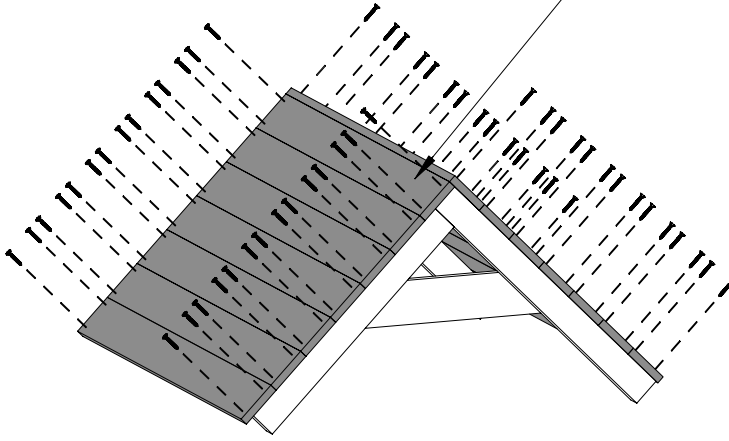

18

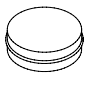
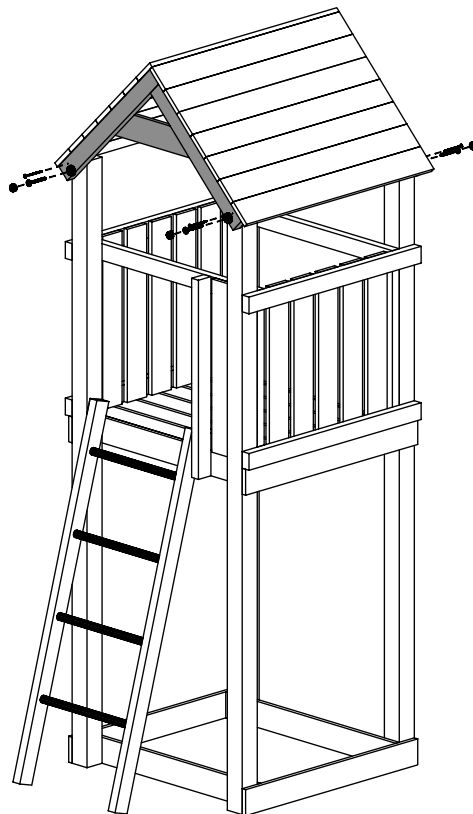
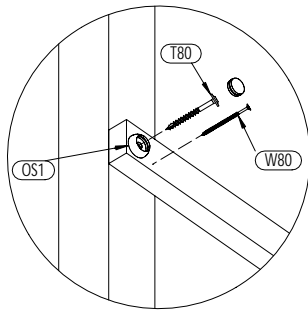
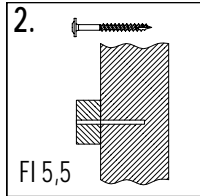
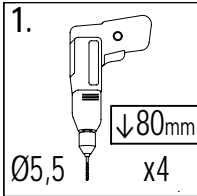

OS1 x4

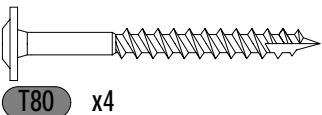
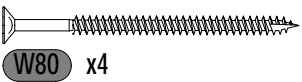

14 MATTI

Zgodnie z normą PN-EN 71 stosuj zalecenia producenta odnośnie odległości oraz metody mocowania poszczególnych elementów
 In compliance with the standard PN-EN 71, apply guidelines of the producer in relation to distances and methods of fastening individual elements

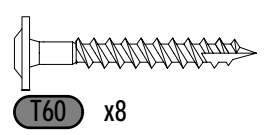
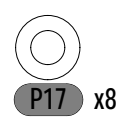
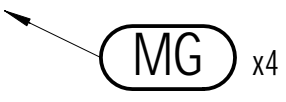
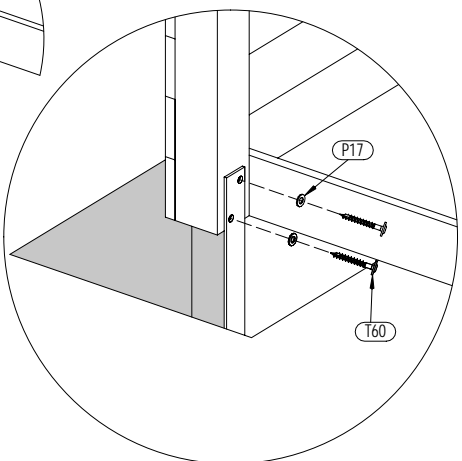
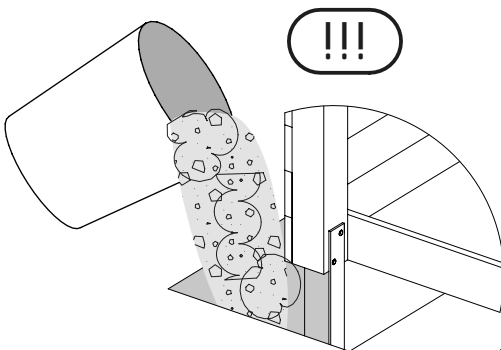
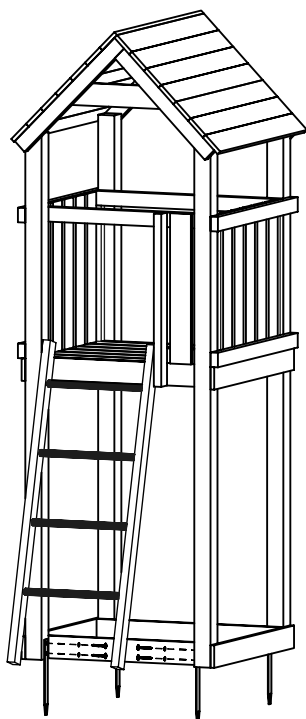
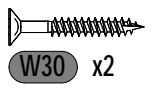
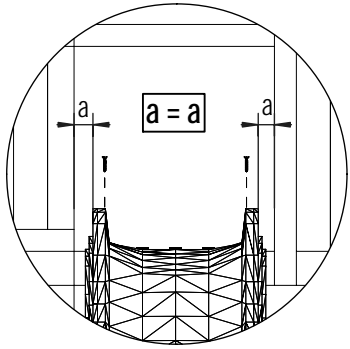
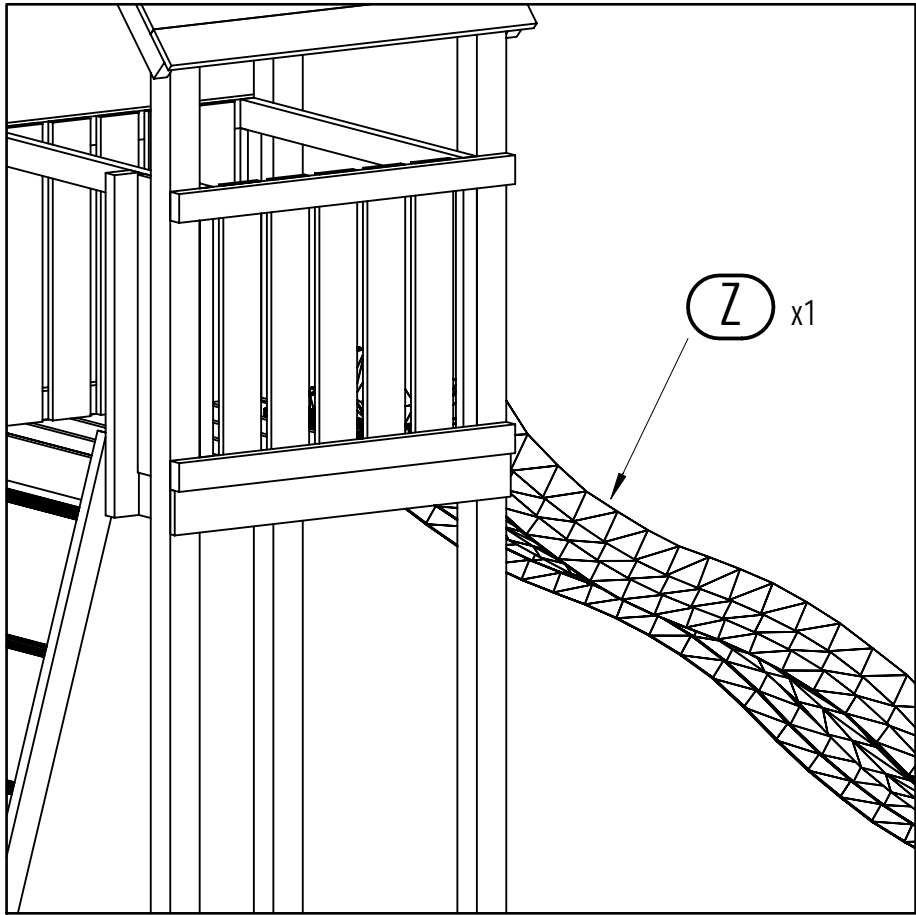

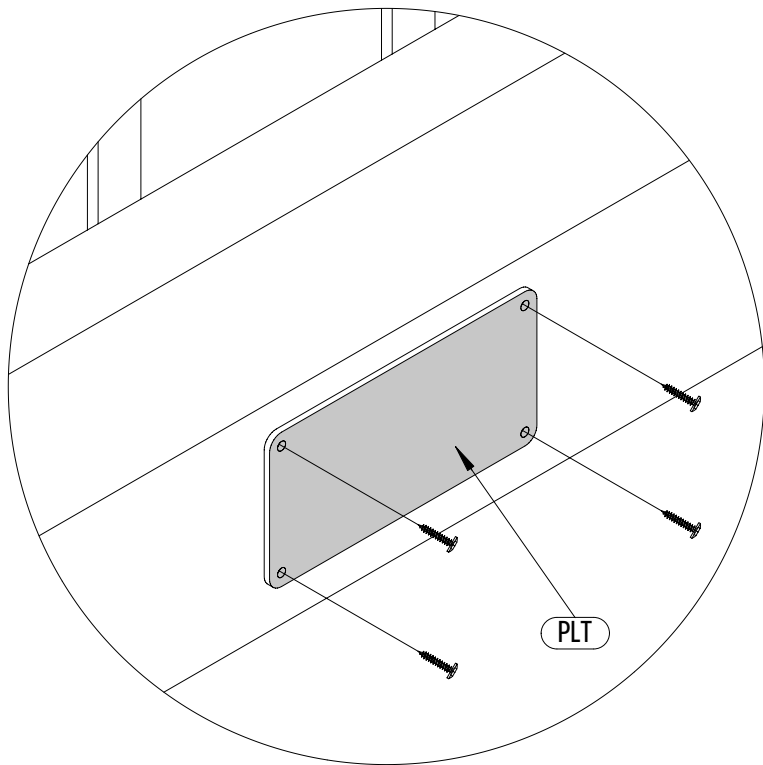
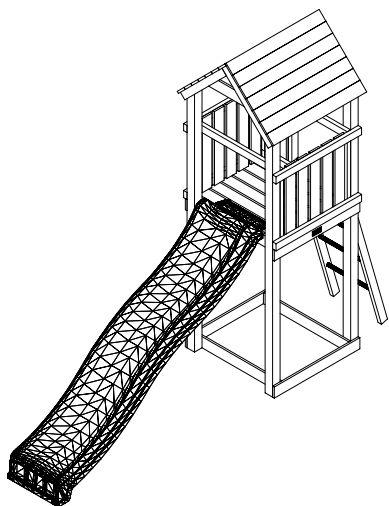

W20 x4